

## User's Guide



# ADI-192 DD

**SyncAlign**<sup>™</sup>

**SyncCheck**<sup>™</sup>

**Intelligent Clock Control**<sup>™</sup>

**SteadyClock**<sup>™</sup>

Hi-Precision 24 Bit / 192 kHz  
8-Channel Triple Universal Format Converter  
8-Channel Sample Rate Converter  
ADAT<sup>®</sup> optical - TDIF<sup>™</sup> - AES/EBU Interface



TDIF-1  
24 Bit Interface

---

▶ **General**

|          |  |    |
|----------|--|----|
| <b>1</b> | <b>Introduction</b> .....                          | 6  |
| <b>2</b> | <b>Package Contents</b> .....                      | 6  |
| <b>3</b> | <b>Brief Description and Characteristics</b> ..... | 6  |
| <b>4</b> | <b>First Usage - Quick Start</b>                   |    |
| 4.1      | Controls and Connectors .....                      | 7  |
| 4.2      | Quick Start .....                                  | 8  |
| 4.3      | The DD plain and simple.....                       | 9  |
| <b>5</b> | <b>Warranty</b> .....                              | 10 |
| <b>6</b> | <b>Appendix</b> .....                              | 10 |

▶ **Usage and Operation**

|          |  |    |
|----------|--|----|
| <b>5</b> | <b>Front Panel Controls</b>                |    |
| 5.1      | INPUT MONITOR .....                        | 14 |
| 5.2      | SRC INPUT .....                            | 14 |
| 5.3      | CLOCK SECTION.....                         | 15 |
| 5.4      | AES OUTPUT .....                           | 16 |
| 5.5      | TDIF OUTPUT .....                          | 16 |
| 5.6      | ADAT OUTPUT .....                          | 16 |
| <b>6</b> | <b>Inputs</b>                              |    |
| 6.1      | AES/EBU.....                               | 17 |
| 6.2      | TDIF .....                                 | 18 |
| 6.3      | ADAT Optical .....                         | 19 |
| <b>7</b> | <b>Outputs</b>                             |    |
| 7.1      | AES/EBU.....                               | 20 |
| 7.2      | TDIF .....                                 | 21 |
| 7.3      | ADAT Optical .....                         | 22 |
| <b>8</b> | <b>The Sample Rate Converter</b>           |    |
| 8.1      | General .....                              | 23 |
| 8.2      | Operation .....                            | 23 |
| 8.3      | Clock Decoupling using the SRC.....        | 25 |
| 8.4      | The SRC as Signal Conditioner .....        | 25 |
| <b>9</b> | <b>Word Clock</b>                          |    |
| 9.1      | Word Clock Input and Output.....           | 26 |
| 9.2      | Technical Description and Background ..... | 27 |
| 9.3      | Cables and Termination.....                | 28 |

▶ **Technical Reference**

|           |                                     |    |
|-----------|-------------------------------------|----|
| <b>10</b> | <b>Technical Specifications</b>     |    |
| 10.1      | Inputs.....                         | 30 |
| 10.2      | Outputs.....                        | 31 |
| 10.3      | Digital .....                       | 31 |
| 10.4      | Sample Rate Converter .....         | 32 |
| 10.5      | General .....                       | 32 |
| 10.6      | Connector Pinouts.....              | 32 |
| 10.7      | Firmware .....                      | 33 |
| <b>11</b> | <b>Technical Background</b>         |    |
| 11.1      | Terminology .....                   | 34 |
| 11.2      | Lock, SyncCheck and SyncAlign ..... | 35 |
| 11.3      | DS – Double Speed .....             | 36 |
| 11.4      | QS – Quad Speed.....                | 36 |
| 11.5      | AES/EBU – SPDIF .....               | 37 |
| 11.6      | Group Delay – I/O Latency .....     | 38 |
| 11.7      | SteadyClock.....                    | 39 |
| <b>12</b> | <b>Block Diagram</b> .....          | 40 |

---

## Important Safety Instructions



### **ATTENTION! Do not open chassis – risk of electric shock**

The unit has non-isolated live parts inside. No user serviceable parts inside. Refer service to qualified service personnel.



### **Mains**

- The device must be earthed – never use it without proper grounding
- Do not use defective power cords
- Operation of the device is limited to the manual
- Use same type of fuse only



To reduce the risk of fire or electric shock do not expose this device to rain or moisture. Prevent moisture and water from entering the device. Never leave a pot with liquid on top of the device. Do not use this product near water, i. e. swimming pool, bathtub or wet basement. Danger of condensation inside – don't turn on before the device has reached room temperature.



### **Installation**

Surface may become hot during operation – ensure sufficient ventilation. Avoid direct sun light and do not place it near other sources of heat, like radiators or stoves. When mounting in a rack, leave some space between this device and others for ventilation.



Unauthorized servicing/repair voids warranty. Only use accessories specified by the manufacturer.



Read the manual completely. It includes all information necessary to use and operate this device.



---

## User's Guide



# ADI-192 DD

### ▶ General

---

## 1. Introduction

With the ADI-192 DD you have an incredibly versatile digital interface to your supply. The successor of the highly successful *ADI-8 DD* is a completely re-engineered device, designed to be the most powerful format and sample rate converter ever. What at first looks like a simple AES/TDIF/ADAT format converter, turns out to be *the* universal problem solver at a closer look. From small project studios to broadcast and television, the *Universal Format Converter* is the perfect link between the formats mostly used today.

As a consequent continuation of RME's world-wide successful ADI series, the 192 DD also contains elaborate technology and the latest integrated circuits. The ADI-192 DD is a uniquely powerful and high-quality device, which will excite you even after many years of operation.

This manual has been divided into three parts:

- The first part is written as quick start guide. Even the first time user will be successfully up and running with most of the typical applications addressed by the ADI-192 DD.
- The second part contains both basic and detailed information on all modes supported by the ADI-192 DD, including sample multiplexing via Double and Quad Wire technology.
- The third part contains useful background information about the methods and technologies found in the ADI-192 DD.

In case you want to dive deeply into the powerful features of the ADI-192 DD, please start with chapter 11.1, Terminology.

## 2. Package Contents

Please check that your ADI-192 DD package contains each of the following:

- ADI-192 DD
- User's Guide
- Power chord

## 3. Brief Description and Characteristics

The ADI-192 DD consists of three 8-channel digital format converters, in a standard 19" box with 1 unit height. The compact device has numerous extraordinary features like Intelligent Clock Control (ICC), SyncCheck, SyncAlign, Bitclock PLL, patchbay functionality and active jitter suppression through SteadyClock. Switchable high-end sample rate converters (SRC) in reference quality allow for both sample rate conversion and clock decoupling on the highest level.

All of the ADI-192 DD's I/Os support 192 kHz/24 bit. Since ADAT optical and TDIF are restricted to 48 kHz, and AES is often limited to 48 or 96 kHz as well, the ADI-192 DD supports the so called *Sample Multiplexing* in a unique way. Be it Double Wire, Quad Wire, S/MUX or S/MUX4 – the ADI-192 DD receives and transmits in all these modes, and turns out to be the world's only sample rate converter that can operate in these modes using all three interface formats.

The format conversion between AES/EBU, ADAT and TDIF operates in all directions at the same time. LEDs of different colours show the present state of incoming and outgoing signals and of the internal processing in a clear way.

The unique Intelligent Clock Control (ICC) allows for a flexible use with internal clock (44.1 up to 192 kHz), external word clock, or the digital input signals, thanks to a clear and easily understandable display of the Lock and Sync states. In short: the ADI-192 DD is a true *Intelligent Audio Solution*.

---

## 4. First Usage – Quick Start

### 4.1 Controls and Connectors

The front of the ADI-192 DD features nine buttons and 48 LEDs, providing all necessary means for a detailed configuration of the unit, plus an optical SPDIF I/O with TOSLINK connectors.

**INPUT MONITOR** indicates a valid input signal separately for each digital input. Additionally, RME's exclusive *SyncCheck* indicates if one of these inputs is locked, but not synchronous to the others. See also chapter 5.1 and 11.2.

**SRC INPUT** defines source and frequency range of the sample rate converter's input signal.

In the **CLOCK SECTION** the current clock reference and frequency multiplier is chosen.

In the **AES OUTPUT** section, source, channel status and the optional sample multiplexing of the AES/EBU outputs is selected.

**TDIF OUTPUT** defines which input signal appears at the TDIF output.

**ADAT OUTPUT** defines which input signal appears at the ADAT output.

The optical **SPDIF I/O** allows to use the first AES I/O port via TOSLINK cable.

The rear of the ADI-192 DD provides all the connections: eight AES/EBU (XLR), four ADAT optical (TOSLINK), two TDIF (D-sub 25), three word clock (BNC), and mains power.

**ADAT I/O MAIN** (TOSLINK): Standard ADAT optical port.

**ADAT I/O AUX** (TOSLINK): Transmits further channels when sample multiplexing is active.

**AES/EBU INPUTS** (XLR): Transformer-coupled, high sensitivity, therefore accepts SPDIF signals as well.

**AES/EBU OUTPUTS** (XLR): Transformer-coupled, fully AES/EBU compatible.

**TDIF-1 MAIN** (D-sub 25): Standard TDIF port.

**TDIF-1 AUX** (D-sub 25): Transmits further channels when sample multiplexing is active.

**WORD IN** (BNC): A push switch allows to activate internal termination (75 Ohms). When termination is activated the yellow LED besides the switch lights up.

**WORD OUT STD** (BNC): Standard word clock output.

**WORD OUT TDIF** (BNC): Special word clock output for TDIF-based devices.

**IEC receptable** for power connection. The specially developed, internal hi-performance switch mode power supply makes the ADI-192 DD operate in the range of 100V to 240V AC. It is short-circuit-proof, has an integrated line filter, is fully regulated against voltage fluctuations, and suppresses mains interference.

## 4.2 Quick Start

In the INPUT MONITOR section 19 LEDs provide detailed information about the status of the digital input signals. Displayed are Lock (flashing) and Sync (constantly lit), the frequency range (Double or Quad Speed), a possible S/MUX indication on the ADAT input (DW), and the presence of audio data within the signal (Level).

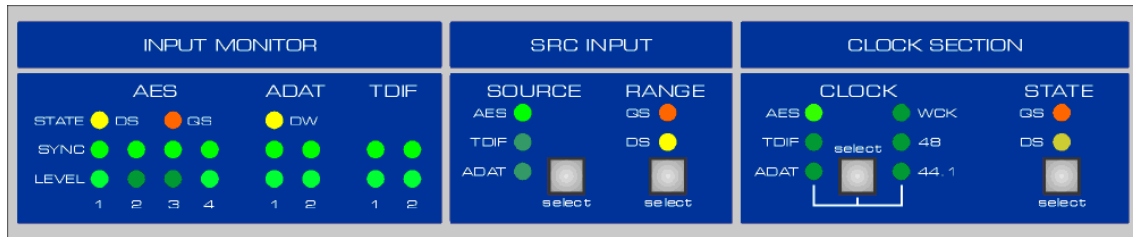

SRC INPUT SOURCE is used to select the input signal of the sample rate converter. With several special formats the unit can't detect the input signal's effective sample rate. Therefore the frequency range has to be set manually via the RANGE button. In some cases the unit takes over control, or limits the available choices intelligently. Example: With an input signal AES 192 kHz the RANGE QS LED automatically lights up and can't be switched off. However with an input signal ADAT 48 kHz the unit can't know whether it receives 48 kHz (no LED), 96 kHz in S/MUX format (DS), or 192 kHz as S/MUX4 (QS). So the right choice has to be performed manually with the RANGE button.

The source and frequency range of the unit's clock is defined in the CLOCK SECTION. The button CLOCK steps through the choices external clock (AES, TDIF, ADAT and word) and internal clock (44.1 or 48 kHz). The button STATE defines the sample rate range for both internal and external clock. DS gives 88.2 and 96 kHz, QS gives 176.4 and 192 kHz respectively.

The input signal for each of the three outputs (output formats) is selected in the three OUTPUT sections. Selecting the same input in the OUTPUT section as in the SRC INPUT SOURCE section, the LED SRC indicates an activated sample rate conversion.

The section AES OUTPUT allows for further settings. The AES output signal can be chosen to have Professional or Consumer status. Additionally at 88.2 and 96 kHz the output format Double Wire (4 channels), and at 176.4 and 192 kHz Quad Wire (2 channels) can be selected.

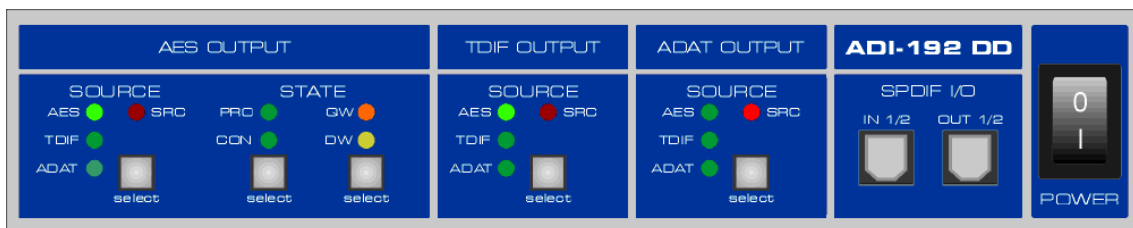

Operating the ADI-192 DD with typical consumer devices is possible via the optical TOSLINK jacks in the SPDIF I/O section. The optical input automatically replaces the rear XLR input AES1, as soon as an SPDIF signal is detected. The optical output sends out the same signal as the rear AES1 XLR output, i.e. channels 1/2, but carries a fixed channel status *Consumer*.

The ADI-192 DD stores all settings before switching off and sets them automatically when switching on the next time.



---

### 4.3 The DD plain and simple

The user interface of the ADI-192 DD is characterized by a clearly structured architecture and an unambiguous labelling of the front and rear sides. Numerous LEDs show the state of the device and of all incoming and outgoing signals in a strictly logical way.

A simplified block diagram of the ADI-192 DD shows in an easy to understand way, how the different format converters work together and how they can be used in practice.

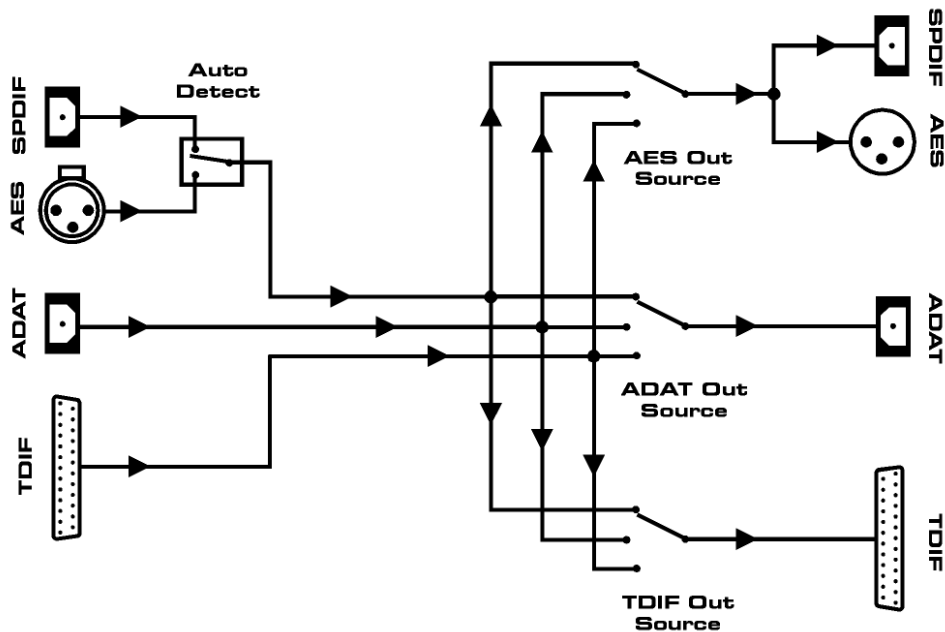

The three input formats AES/SPDIF, ADAT and TDIF on the left side are sent to three *Output Source* selectors each. Using these selectors, the three outputs on the right side gain access to any of the three inputs. As all three selectors operate independently, all three outputs can even use the same input signal, so AES is converted to AES, TDIF and ADAT at the same time – just an example. Any combination that one can imagine is allowed.

The big block diagram also printed on the unit's cover (see chapter 12) shows further details, like the AES input jacks, Double Speed and Quad Speed conversion, and the clock control.

The big block diagram especially shows the way of operation of the ADI-192 DD's 8-channel sample rate converter. The SRC has a choice of access to the input formats AES/SPDIF, ADAT or TDIF. It is not possible to use the SRC with more than one format at a time. The SRC processes either AES/SPDIF, ADAT or TDIF. But the SRC's output signal is available at the AES/SPDIF, ADAT and TDIF outputs simultaneously.

The unit's user surface includes a smart improvement not being shown in the block diagram. When an OUTPUT is set to the same SOURCE that is selected as SOURCE of the SRC, the OUTPUT SOURCE automatically changes to SRC. The fourth choice shown in the block diagram, the SRC bus, is selected from the device itself, and not selectable via the OUTPUT button.

---

## 5. Warranty

Each individual ADI-192 DD undergoes comprehensive quality control and a complete test at IMM before shipping. . The usage of high grade components should guarantee a long and trouble-free operation of the unit.

If you suspect that your product is faulty, please contact your local retailer.

Audio AG grants a limited manufacturer warranty of 6 months from the day of invoice showing the date of sale. The length of the warranty period is different per country. Please contact your local distributor for extended warranty information and service. Note that each country may have regional specific warranty implications.

In any case warranty does not cover damage caused by improper installation or maltreatment - replacement or repair in such cases can only be carried out at the owner's expense.

No warranty service is provided when the product is not returned to the local distributor in the region where the product had been originally shipped.

Audio AG does not accept claims for damages of any kind, especially consequential damage. Liability is limited to the value of the ADI-192 DD. The general terms of business drawn up by Audio AG apply at all times.

## 6. Appendix

RME news and further information can be found on our website:

<http://www.rme-audio.com>

Distributor: Audio AG, Am Pfanderling 60, D-85778 Haimhausen, Tel.: (49) 08133 / 91810

Manufacturer:

IMM Elektronik GmbH, Leipziger Strasse 32, D-09648 Mittweida

## Trademarks

All trademarks, registered or otherwise, are the property of their respective owners. RME, DIGICheck and Hammerfall are registered trademarks of RME Intelligent Audio Solutions. DIGI96, SyncAlign, ZLM, SyncCheck, TMS, TotalMix and ADI-192 DD are trademarks of RME Intelligent Audio Solutions. Alesis and ADAT are registered trademarks of Alesis Corp. ADAT optical is a trademark of Alesis Corp. Microsoft, Windows, Windows XP, Windows Vista and Windows 7 are registered trademarks or trademarks of Microsoft Corp. S/MUX is copyright Sonorus.

Copyright © Matthias Carstens, 02/2011. Version 1.4

All entries in this User's Guide have been thoroughly checked, however no guarantee for correctness can be given. RME cannot be held responsible for any misleading or incorrect information provided throughout this manual. Lending or copying any part or the complete manual or its contents as well as the software belonging to it is only possible with the written permission from RME. RME reserves the right to change specifications at any time without notice.

---

## CE / FCC Compliance

### CE

This device has been tested and found to comply with the limits of the European Council Directive on the approximation of the laws of the member states relating to electromagnetic compatibility according to RL2004/108/EG, and European Low Voltage Directive RL2006/95/EG.

### FCC

This equipment has been tested and found to comply with the limits for a Class B digital device, pursuant to Part 15 of the FCC Rules. These limits are designed to provide reasonable protection against harmful interference in a residential installation. This equipment generates, uses, and can radiate radio frequency energy and, if not installed and used in accordance with the instructions, may cause harmful interference to radio communications. However, there is no guarantee that interference will not occur in a particular installation. If this equipment does cause harmful interference to radio or television reception, which can be determined by turning the equipment off and on, the user is encouraged to try to correct the interference by one or more of the following measures:

- Reorient or relocate the receiving antenna.
- Increase the separation between the equipment and receiver.
- Connect the equipment into an outlet on a circuit different from that to which the receiver is connected.
- Consult the dealer or an experienced radio/TV technician for help.

### RoHS

This product has been soldered lead-free and fulfils the requirements of the RoHS directive.

### ISO 9001

This product has been manufactured under ISO 9001 quality management. The manufacturer, IMM Elektronik GmbH, is also certified for ISO 14001 (Environment) and ISO 13485 (medical devices).

## Note on Disposal

According to the guide line RL2002/96/EG (WEEE – Directive on Waste Electrical and Electronic Equipment), valid for all european countries, this product has to be recycled at the end of its lifetime.

In case a disposal of electronic waste is not possible, the recycling can also be done by IMM Elektronik GmbH, the manufacturer of the ADI192 DD.

For this the device has to be sent **free to the door** to:

IMM Elektronik GmbH  
Leipziger Straße 32  
D-09648 Mittweida  
Germany



Shipments not prepaid will be rejected and returned on the original sender's costs.



---

## User's Guide



# ADI-192 DD

### ▶ Usage and Operation

---

## 5. Front panel Controls

### 5.1 INPUT MONITOR

The status of the inputs is displayed by 19 LEDs. The section INPUT MONITOR helps to avoid errors caused by wrong, missing or not correctly connected inputs, and makes handling the digital formats much easier.

#### General

Each input has its own SYNC LED. If a valid input signal is applied, SyncCheck is active automatically. When more than one input signal is present, the input with the lowest number serves as reference. SyncCheck takes the chosen clock (internal, external, etc.) as reference and compares it with the input clocks. Inputs which are not synchronous will be signalled by flashing of the corresponding SYNC LED.

The LEVEL LED lights up as soon as the digital signal carries an information other than digital zero. The channel doesn't matter. So with ADAT there is only one channel of audio information necessary for the LED to light up. The amount of level is not indicated.

#### AES

An AES/EBU or SPDIF signal in the range of 60 kHz to 100 kHz will turn the DS (Double Speed) LED on. An AES/EBU or SPDIF signal in the range of 162 kHz to 200 kHz will turn the QS (Quad Speed) LED on.

#### ADAT

An ADAT signal with S/MUX signalling will let the DW (Double Wire) LED light up. Unfortunately this information is insufficiently standardised, and is even set falsely from several devices. Therefore the DW LED is just a user information, but does not cause any action in the ADI-192 DD. Devices from RME always send out a correct signalling.

### 5.2 SRC INPUT

The button SRC INPUT SOURCE defines the data path in which the sample rate converter will be inserted: AES, TDIF or ADAT. With no LED lit, the SRC is deactivated. Selecting the same input in the OUTPUT section as in the SRC INPUT SOURCE section, the LED SRC indicates an activated sample rate conversion. Selecting the function SRC in the OUTPUT sections is not necessary.

In many input formats, the input signal's effective sample rate stays unclear because of possible *sample multiplexing*. Therefore the frequency range has to be defined manually with the RANGE button:

#### No LED (Single Speed)

The effective sample frequency is in the range of 32 kHz up to 48 kHz.

#### DS (Double Speed)

The effective sample frequency is in the range of 64 kHz up to 96 kHz.

#### QS (Quad Speed)

The effective sample frequency is in the range of 176.4 kHz up to 192 kHz.

#### DS + QS (Multi-range Mode)

The effective sample frequency is in the range of 32 kHz up to 192 kHz. Note: keep the RANGE button pressed to activate this mode. Only Single Wire input signals are supported. Can only be activated when AES is selected.



---

The function *RANGE* tells the SRC which frequency its **input signal** has. The frequency of its **output signal** (the frequency the input signal shall be converted to) is defined in the **CLOCK SECTION**.

More information is found in chapter 8, Sample Rate Converter.

### 5.3 CLOCK SECTION

The source and frequency of the unit's clock is configured in the **CLOCK SECTION**. The button **CLOCK** lets you step through the options external clock (AES, TDIF, ADAT, word) and internal clock (44.1 or 48 kHz). The button **STATE** sets internal, but also the external sample rate to double or quadruple of the basic sample rate.

#### **AES, TDIF, ADAT (Slave Mode)**

ADAT, TDIF or AES input can serve as the clock reference. The choice is independent from the processed audio signal. If the unit is currently used as TDIF to ADAT converter, the clock source can still be AES, given that a valid AES signal is available. A missing or invalid clock source signal is indicated by flashing of the corresponding LED.

#### **WCK (Slave Mode)**

Selects the word clock input as clock reference. The LED flashes in case the word clock signal is missing or invalid.

#### **44.1, 48 (Master Mode)**

Activates the internal clock at 44.1 kHz or 48 kHz. Using the button **STATE** a choice of **DS** gives 88.2 and 96 kHz, a choice of **QS** gives 176.4 and 192 kHz respectively.



*With a setting of 44.1 and 48 (internal clock) it is mandatory that the clock rate of the sources is synchronous to the ADI-192 DD. Therefore the external device has to be synchronized to the ADI-192 DD's word clock out or AES/TDIF/ADAT out.*

The ADI-192 DD thus has to be master, all devices connected to it slave (exception: the SRC mode). In order to avoid clicks and drop outs due to faulty or missing synchronicity, a special process called *SyncCheck* compares the incoming data and the ADI-192 DD's internal clock. The **SYNC** state is indicated by a flashing (error) or constantly lit (OK) LED.

The button **STATE** is used to configure the ADI-192 DD, and with this all of its outputs, to the frequency ranges Single Speed, Double Speed or Quad Speed.

#### **Single Speed (no LED)**

All outputs carry a signal in the range of 32 kHz up to 48 kHz.

#### **Double Speed (LED DS)**

All AES outputs carry a signal in the range of 64 kHz up to 96 kHz, except for an activated option **DW** in AES OUTPUT. ADAT and TDIF stay at no higher than 48 kHz, but the data is transmitted in the S/MUX format.

#### **Quad Speed (LED QS)**

All AES outputs carry a signal in the range of 176.4 kHz up to 192 kHz, except for an activated option **DW** or **QW** in AES OUTPUT. ADAT and TDIF stay at no higher than 48 kHz, but the data is transmitted in the S/MUX4 format.

#### **Follow Clock**

In this special mode the ADI-192 DD follows the input clock of AES and Word automatically over all three ranges. So at 96 kHz the **DS** LED automatically lights up, at 192 kHz the **QS** LED. A manual configuration via the **STATE** button is no longer required. This function is deactivated for the ADAT and TDIF input, as the sample rate range of these formats can not be detected automatically.

---

Activation of Follow Clock: while the firmware version is shown press the CLOCK STATE button. Both LEDs DS/QS light up. Deactivation: same, both LEDs stay dark.

## 5.4 AES OUTPUT

The input signal of the AES outputs is selected in the OUTPUT section. With no LED lit (no input selected) the unit provides an empty frame signal of the current sample frequency. A flashing LED indicates an invalid or missing input signal. Selecting the same input in the OUTPUT section as in the SRC INPUT SOURCE section, the LED SRC indicates an activated sample rate conversion.

AES STATE PRO (Professional) is default for the AES outputs. Selecting CON (Consumer) provides the output signal with an SPDIF-compatible channel status.

The outputs of the ADI-192 DD support all currently known formats in the range of 32 kHz up to 192 kHz. The current output format is defined by the button STATE in the AES OUTPUT section:

### No LED (Single Wire)

8 channels 32 kHz – 192 kHz. 2 channels per AES wire. The effective sample frequency equals the clock on the AES wire.

### DW (Double Wire)

4 channels 88.2 – 192 kHz. 1 channel per AES wire. The effective sample frequency is double the clock of the AES wire.

### QW (Quad Wire)

2 channels 176.4 – 192 kHz. 1 channel via 2 AES wires. The effective sample frequency is four times the clock of the AES wire.

All these conversions are lossless. Only the existing samples are spread on all the channels.

## 5.5 TDIF OUTPUT

The input signal of the TDIF output is selected in the OUTPUT section. With no LED lit (no input selected) the unit provides an empty frame signal of the current sample frequency. A flashing LED indicates an invalid or missing input signal. Selecting the same input in the OUTPUT section as in the SRC INPUT SOURCE section, the LED SRC indicates an activated sample rate conversion.



*When selecting SOURCE TDIF in the TDIF OUTPUT section, some devices will generate audio feedback, because in such a case their input and output is directly connected by the ADI-192 DD.*

## 5.6 ADAT OUTPUT

The input signal of the ADAT output is selected in the OUTPUT section. With no LED lit (no input selected) the unit provides an empty frame signal of the current sample frequency. A flashing LED indicates an invalid or missing input signal. Selecting the same input in the OUTPUT section as in the SRC INPUT SOURCE section, the LED SRC signals an active sample rate conversion.



---

## 6. Inputs

### 6.1 AES/EBU

At the rear side of the ADI-192 DD there are four XLR sockets for the AES/EBU inputs. Every input is transformer-balanced and ground-free. Channel status and copy protection are being ignored.

Thanks to a highly sensitive input stage, also SPDIF signals can be processed by using a simple cable adapter phono/XLR. To achieve this, pins 2 and 3 of a male XLR plug are connected individually to the two pins of a phono plug. The cable shielding is only connected to pin 1 of the XLR - not to the phono plug.

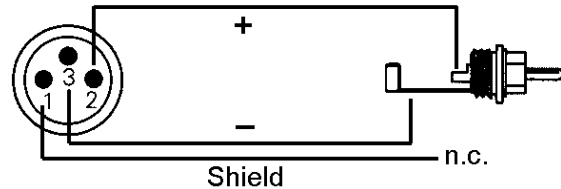

The inputs can be used in any combination, e. g. it is sufficient to connect an input signal only to input 3. In slave mode, this input is automatically being used as clock source. If more than one signal is present, the one furthest left is being used as clock source, i. e. the active input with the lowest number.

If only one AES input is used, the ADI-192 DD copies the stereo signal to all AES outputs, realizing a useful distribution mode where one AES signal is sent to four devices at the same time (splitter/distributor). The distribution mode is also available when using the front SPDIF input. Please note that this special function is only active in Single Speed operation, but also with SRC activated.

The ADI-192 DD supports all currently known formats in the range of 32 kHz up to 192 kHz, including sample multiplexing:

- Single Wire: 8 channels 32 kHz – 192 kHz. 2 channels per AES wire. The effective sample frequency equals the clock on the AES wire.
- Double Wire: 4 channels 88.2 kHz – 192 kHz. 1 channel per AES wire. The effective sample frequency is double the clock of the AES wire.
- Quad Wire: 2 channels 176.4 kHz – 192 kHz. 1 channel via 2 AES wires. The effective sample frequency is four times the clock of the AES wire.

Rearranging the formats Double and Quad Wire to Single Wire is lossless, the existing samples are just re-ordered again. Information on the distribution of the samples in Double and Quad Wire mode is found in chapter 7.1, Outputs AES.

The optional hi-end 8-channel sample rate converter can be used both for a conversion of the sample rate and for clock decoupling of the AES/EBU inputs. See chapter 8, Sample Rate Converter.

#### Emphasis

AES/EBU and SPDIF can contain Emphasis information. Audio signals with Emphasis have a strong high frequency boost and thus require a high frequency attenuation on playback. If one of the inputs detects Emphasis, this information is coded into all AES outputs, i.e. globally passed on.



*Emphasis is not available within the ADAT standard! This information is neither passed on to the ADAT output, nor taken into account later on for acoustic transmission!*

---

## 6.2 TDIF

The ADI-192 DD has two TDIF-1 ports. In standard operation only the port labelled MAIN is used. Higher sample rates than 48 kHz are realized by sample multiplexing. When using more than four channels at Double Speed or two channels at Quad Speed, the port labelled AUX has to be used as well.

The TDIF-1 connectors of the ADI-192 DD are fully compatible with all devices offering such an interface\*. RME's exclusive SyncCheck verifies synchronous operation when using both TDIF ports. The connection is done through a special TDIF cable, available at your local dealer (Tascam part number PW-88D).

### TDIF-1 MAIN

Interface for the first or only device with a TDIF-1 interface. Carries the channels 1 to 8. When transmitting a Double Speed signal MAIN carries the channels 1 to 4, in case of Quad Speed channels 1 and 2.

### TDIF-1 AUX

Additional port for transmission of channels 5 to 8 in Double, or 3 and 4 in Quad Speed mode.

With input signals in the Double Speed range, the SRC (RANGE) or the Clock Section (STATE) have to be switched into DS mode manually, depending on the current application. Each port carries the data of 4 channels only, for up to 8 channels MAIN *and* AUX have to be used. 16 input channels 44.1/48 kHz are converted to 8 channels 88.2/96 kHz as follows:

| Channel Port | 1/2 MAIN | 3/4 MAIN | 5/6 MAIN | 7/8 MAIN | 1/2 AUX | 3/4 AUX | 5/6 AUX | 7/8 AUX |
|--------------|----------|----------|----------|----------|---------|---------|---------|---------|
| Samples      | 1a/b     | 2a/b     | 3a/b     | 4a/b     | 5a/b    | 6a/b    | 7a/b    | 8a/b    |

With input signals in the Quad Speed range, the SRC (RANGE) or the Clock Section (STATE) have to be switched into QS mode manually, depending on the current application. Each port carries the data of 2 channels only, for up to 4 channels MAIN *and* AUX have to be used. 16 input channels 44.1/48 kHz are converted to 4 channels 176.4/192 kHz as follows:

| Channel Port | 1/2 MAIN | 3/4 MAIN | 5/6 MAIN | 7/8 MAIN | 1/2 AUX | 3/4 AUX | 5/6 AUX | 7/8 AUX |
|--------------|----------|----------|----------|----------|---------|---------|---------|---------|
| Samples      | 1a/b     | 1c/d     | 2a/b     | 2c/d     | 3a/b    | 3c/d    | 4a/b    | 4c/d    |

All the described conversions are lossless. The existing samples are just spread or re-united between the channels.

### General Notes

#### \*DA98HR

The Quad Wire method of the ADI-192 DD allows to record two channels at up to 192 kHz with every (!) DTRS device. Unfortunately Tascam's TDIF implementation is incompatible to Quad Wire, as the samples are not transmitted in the order of 1-2-3-4, but 1-3-2-4. In case the special 192 kHz mode of the DA-98HR shall be used, the machine should be connected and used with the ADI-192 DD via AES.

### TDIF and Word Clock

When the ADI-192 DD is slave no additional word clock connection is necessary. In case DA88 and/or DA38 are slave the word clock output TDIF of the ADI-192 DD has to be connected to the word clock input of the first (master) recorder. When using more than one recorder all machines should be connected with a special sync cable (Tascam part number PW-88S).

### Emphasis

The ADI-192 DD's TDIF interface supports Emphasis. Please note that an Emphasis indication is lost with transfers to ADAT optical. Emphasis does not exist in the ADAT specification.

---

## 6.3 ADAT Optical

The ADI-192 DD has two ADAT optical inputs. In standard operation only the port labelled MAIN is used. Higher sample rates than 48 kHz are realized by sample multiplexing. When using more than four channels at Double Speed or two channels at Quad Speed, the port labelled AUX has to be used as well.

The ADAT optical inputs of the ADI-192 DD are fully compatible with all ADAT optical outputs. RME's unsurpassed Bitclock PLL prevents clicks and drop outs even in extreme varipitch operation, and guarantees a fast and sample accurate lock to the digital input signal. A standard TOSLINK cable is sufficient for connection.

### ADAT MAIN

Interface for the first or only device sending an ADAT signal to the ADI-192 DD. Carries the channels 1 to 8. When receiving an S/MUX signal, MAIN carries the channels 1 to 4, in case of S/MUX4 MAIN carries channels 1 and 2.

### ADAT AUX

Additional port for receiving channels 5 to 8 in S/MUX, or 3 and 4 in S/MUX4 mode.

With input signals encoded as S/MUX, the SRC (RANGE) or the Clock Section (STATE) have to be switched into DS mode manually, depending on the current application. Each port carries the data of 4 channels only, for up to 8 channels MAIN *and* AUX have to be used. 16 input channels 44.1/48 kHz are converted to 8 channels 88.2/96 kHz as follows:

| ADAT Port | 1/2 MAIN | 3/4 MAIN | 5/6 MAIN | 7/8 MAIN | 1/2 AUX | 3/4 AUX | 5/6 AUX | 7/8 AUX |
|-----------|----------|----------|----------|----------|---------|---------|---------|---------|
| Samples   | 1a/b     | 2a/b     | 3a/b     | 4a/b     | 5a/b    | 6a/b    | 7a/b    | 8a/b    |

With input signals encoded as S/MUX4, the SRC (RANGE) or the Clock Section (STATE) have to be switched into QS mode manually, depending on the current application. Each port carries the data of 2 channels only, for up to 4 channels MAIN *and* AUX have to be used. 16 input channels 44.1/48 kHz are converted to 4 channels 176.4/192 kHz as follows:

| ADAT Port | 1/2 MAIN | 3/4 MAIN | 5/6 MAIN | 7/8 MAIN | 1/2 AUX | 3/4 AUX | 5/6 AUX | 7/8 AUX |
|-----------|----------|----------|----------|----------|---------|---------|---------|---------|
| Samples   | 1a/b     | 1c/d     | 2a/b     | 2c/d     | 3a/b    | 3c/d    | 4a/b    | 4c/d    |

All these conversions are lossless. The existing samples are just re-united across the channels.

---

## 7. Outputs

### 7.1 AES/EBU

At the rear side of the ADI-192 DD there are four XLR sockets as AES/EBU outputs. Each output is transformer-balanced, ground-free and compatible to all devices with AES/EBU ports. Connection is accomplished using balanced cables with XLR plugs.

If AES STATE PRO (Professional) is chosen, the output level is almost 5 Volt. If CON (Consumer) is chosen, the output signal will have a channel status compatible to SPDIF. As far as we know, every SPDIF device should be capable of handling an input signal of up to 5 Volt instead of the usual 0.5 Volt. Nevertheless the output level will be reduced to 2 Volt when CON is selected.

Connecting devices with coaxial SPDIF ports to the ADI-192 DD is accomplished by a simple cable adapter XLR/phono. Pins 2 and 3 of a female XLR plug are connected individually to the two pins of a phono plug. The cable shielding is only connected to pin 1 of the XLR - not to the phono plug.

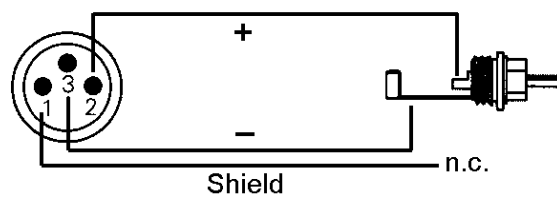

Besides the audio data, digital signals in SPDIF or AES/EBU format contain a channel status coding, which is being used for transmitting further information. The output signal coding of the ADI-192 DD has been implemented according to AES3-1992 Amendment 4:

- 32 kHz, 44.1 kHz, 48 kHz, 64 kHz, 88.2 kHz, 96 kHz, 176.4 kHz, 192 kHz according to the current sample rate
- Audio use
- No Copyright, Copy permitted
- Format Consumer or Professional
- Category General, Generation not indicated
- 2-Channel, No Emphasis or 50/15  $\mu$ s
- Single Channel Double Sampling Frequency Mode (Double Wire)
- Aux Bits Audio use, 24 Bit
- Origin: A192

 *Note that most consumer HiFi equipment (with optical or phono SPDIF inputs) will only accept signals in 'Consumer' format!*

The status 'Professional' should always be active when sending data to a device with AES/EBU inputs (when the XLR connectors are used).

 *If only one AES input is used, the ADI-192 DD automatically activates a distribution mode. The single stereo signal will be copied to all four AES outputs.*

This realizes a useful distribution mode, sending one AES signal to four devices at the same time (splitter/distributor). The distribution mode is also available when using the front SPDIF input. Please note that this special function is only active in Single Speed operation, but also with SRC activated.

The outputs of the ADI-192 DD support all currently known formats in the range of 32 kHz up to 192 kHz. The current output format is defined by the button STATE in the AES OUTPUT section:

- Single Wire (no LED): 8 channels 32 kHz – 192 kHz. 2 channels per AES wire. The effective sample frequency equals the clock on the AES wire.
- Double Wire (LED DW): 4 channels 88.2 kHz – 192 kHz. 1 channel per AES wire. The effective sample frequency is double the clock of the AES wire.
- Quad Wire (LED QW): 2 channels 176.4 kHz – 192 kHz. 1 channel via 2 AES wires. The effective sample frequency is four times the clock of the AES wire.

All these conversions are lossless. Only the existing samples are spread on all the channels.

The options DW and QW are intelligently coupled with the choice of DS/QS in the CLOCK SECTION. When the unit operates in Single Speed mode, neither DW nor QW can be selected. When the unit operates in Double Speed mode, SW (Single Wire, no LED) or DW can be selected. When the unit operates in Quad Speed mode, all three options SW, DW and QW are available.

The distribution of the samples performed in the Double Wire mode equals the S/MUX method and is done as follows:

|                     |            |            |            |            |            |            |            |            |
|---------------------|------------|------------|------------|------------|------------|------------|------------|------------|
| <b>Channel Port</b> | <b>L 1</b> | <b>R 1</b> | <b>L 2</b> | <b>R 2</b> | <b>L 3</b> | <b>R 3</b> | <b>L 4</b> | <b>R 4</b> |
| <b>Samples</b>      | <b>1a</b>  | <b>1b</b>  | <b>2a</b>  | <b>2b</b>  | <b>3a</b>  | <b>3b</b>  | <b>4a</b>  | <b>4b</b>  |

The distribution of the samples performed in the Quad Wire mode equals the S/MUX4 method and is done as follows:

|                     |            |            |            |            |            |            |            |            |
|---------------------|------------|------------|------------|------------|------------|------------|------------|------------|
| <b>Channel Port</b> | <b>L 1</b> | <b>R 1</b> | <b>L 2</b> | <b>R 2</b> | <b>L 3</b> | <b>R 3</b> | <b>L 4</b> | <b>R 4</b> |
| <b>Samples</b>      | <b>1a</b>  | <b>1b</b>  | <b>1c</b>  | <b>1d</b>  | <b>2a</b>  | <b>2b</b>  | <b>2c</b>  | <b>2d</b>  |

## 7.2 TDIF

The TDIF port includes both input and output. Therefore all the information found in chapter 6.3 applies here as well.

Without sample multiplexing being active, the port AUX is operated synchronously, but does not provide any audio data (empty frame).

 *When selecting SOURCE TDIF in the TDIF OUTPUT section, some devices will generate audio feedback, because in such a case their input and output is directly connected by the ADI-192 DD.*

The Quad Wire method of the ADI-192 DD allows to record two channels at up to 192 kHz with every (!) DTRS device.

Unfortunately Tascam's TDIF implementation is incompatible to Quad Wire, as the samples are not transmitted in the order of 1-2-3-4, but 1-3-2-4. In case the special 192 kHz mode of the DTRS machine DA-98HR shall be used, the machine should be connected and used with the ADI-192 DD via AES.

---

## 7.3 ADAT Optical

The ADI-192 DD provides two digital outputs in ADAT optical format. In standard operation only the port labelled MAIN is used. The port AUX is operated synchronously, but does not provide any audio data (empty frame). Higher sample rates than 48 kHz are realized by sample multiplexing. When using more than four channels at Double Speed or two channels at Quad Speed, the port labelled AUX has to be used as well.

The ADAT optical outputs of the ADI-192 DD are fully compatible to all ADAT optical inputs. A standard TOSLINK cable is sufficient for connection.

### ADAT MAIN

Interface for the first or only device receiving an ADAT signal from the ADI-192 DD. Carries the channels 1 to 8. When sending an S/MUX signal, MAIN carries the channels 1 to 4, in case of S/MUX4 MAIN carries channels 1 and 2.

### ADAT AUX

Additional port for a transmission of channels 5 to 8 in S/MUX, or 3 and 4 in S/MUX4 mode.

When operating in Double Speed mode, data are sent encoded as S/MUX. Each output carries the data of 4 channels only, for up to 8 channels MAIN *and* AUX have to be used. The samples/channels are distributed as follows:

| Channel Port | 1/2 MAIN | 3/4 MAIN | 5/6 MAIN | 7/8 MAIN | 1/2 AUX | 3/4 AUX | 5/6 AUX | 7/8 AUX |
|--------------|----------|----------|----------|----------|---------|---------|---------|---------|
| Samples      | 1a/b     | 2a/b     | 3a/b     | 4a/b     | 5a/b    | 6a/b    | 7a/b    | 8a/b    |

When operating in Quad Speed mode, data are sent encoded as S/MUX4. Each output carries the data of 2 channels only, for up to 4 channels MAIN *and* AUX have to be used. The samples/channels are distributed as follows:

| Channel Port | 1/2 MAIN | 3/4 MAIN | 2a MAIN | 2b MAIN | 3a AUX | 3b AUX | 4a AUX | 4b AUX |
|--------------|----------|----------|---------|---------|--------|--------|--------|--------|
| Samples      | 1a/b     | 1c/d     | 2a/b    | 2c/d    | 3a/b   | 3c/d   | 4a/b   | 4c/d   |

Both conversions are lossless. The existing samples are just spread between the channels.

---

## 8. The Sample Rate Converter

### 8.1 General

The ADI-192 DD includes an eight-channel sample rate converter (SRC). Its technical specifications indicate an exceptional conversion quality, formerly known only from synchronous SRC devices. The ADI-192 DD's SRC is asynchronous, yet provides a phase-locked conversion across all eight channels. If the incoming signals are phase-aligned, the SRC converted output signals are as well. Deviations in the sub-sample range are a thing of the past.

A SRC allows a conversion of the sample rate in real-time. The 24 bit converters used in the ADI-192 DD operate practically without loss of signal quality, so no audible artefacts or noise is added. In fact, the SRC works so well that we could recommend to just leave it on at all times, thus eliminating all clock problems right from the start.

The ADI-192 DD offers a maximum conversion rate of 1:7 or 7:1, respectively. Thus, 192 kHz can be converted to any sample rate down to 32 kHz, and 32 kHz can be converted to any frequency up to 192 kHz.

When using the internal clock, every SRC also works as a jitter killer. However, the ADI-192 DD is equipped with SteadyClock, thus operating as perfect jitter killer with any clock source.

An SRC not only converts sample rates, it also serves as a clock decoupler. With SRC active, even non-synchronizable devices (CD-players, DAT machines, etc.) can be used in a setup of digital devices, just as if they were externally synchronized. The SRC decouples input and output clock, sets the output clock to the common reference, thus allowing the combination of different clock-sources without any clicks or dropouts.

### 8.2 Operation

The button SRC INPUT SOURCE defines the data path in which the sample rate converter will be inserted: AES, TDIF or ADAT. With no LED lit, the SRC is deactivated. Selecting the same input in the OUTPUT section as in the SRC INPUT SOURCE section, the LED SRC indicates an activated sample rate conversion. Selecting the function SRC in the OUTPUT sections is not necessary.

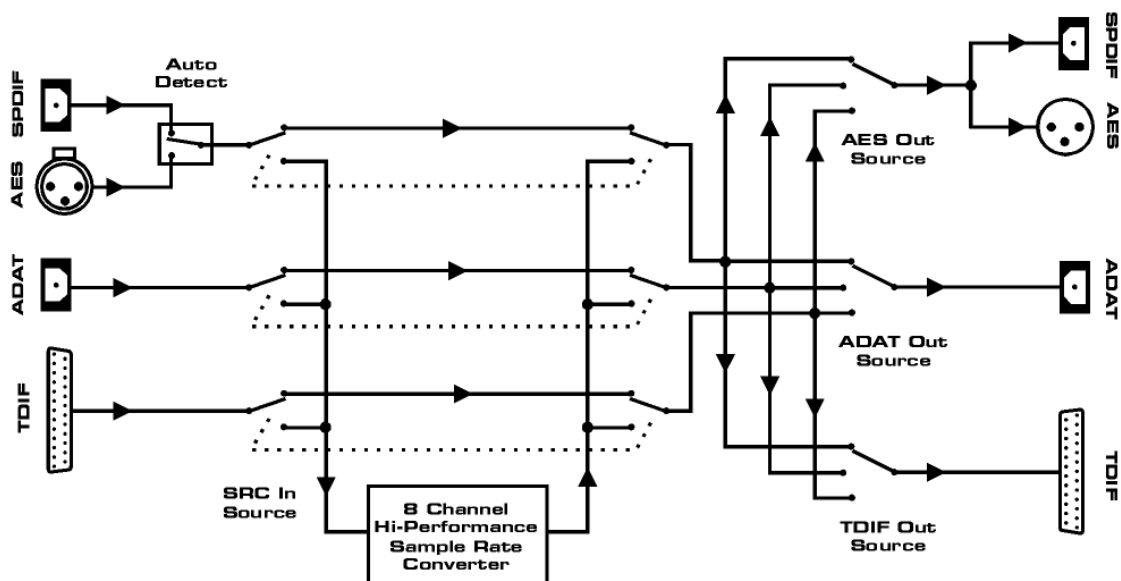

---

In many input formats, the input signal's effective sample rate stays unclear because of possible sample multiplexing. Therefore the frequency range has to be defined manually via the RANGE button:

**No LED (Single Speed):** The effective sample frequency is in the range of 32 kHz up to 48 kHz.

**DS (Double Speed):** The effective sample frequency is in the range of 64 kHz up to 96 kHz.

**QS (Quad Speed):** The effective sample frequency is in the range of 176.4 kHz up to 192 kHz.

#### **DS + QS (Multi-range Mode)**

The effective sample frequency is in the range of 32 kHz up to 192 kHz. Note: keep the RANGE button pressed to activate this mode. Only Single Wire input signals are supported. Can only be activated when AES is selected.



*The function RANGE tells the SRC, which frequency its **input signal** has. The frequency of its **output signal** (the frequency the input signal shall be converted to) is defined in the CLOCK SECTION.*

#### **AES**

An input signal in the range of 32 kHz up to 48 kHz can be a Single Wire transmission, but can also be a multiplex transmission in Double or Quad Wire technology.

In case of Single Wire, the effective sample rate and the AES clock rate are identical, therefore RANGE must be set to the same state as the one shown in the INPUT MONITOR section. With Single Speed, no LED is lit, with Double Speed both DS LEDs must be lit, and with QS, both QS LEDs must be lit.

There are two cases in which the device will intelligently limit your choices. At an input signal of 192 kHz, the QS LED will light up automatically, and can't be deselected. At 96 kHz, only DS and QS can be selected, since the audio signal can't be 48 kHz. At 48 kHz however, the device can not determine whether the signal is 48 kHz, 96 kHz Double Wire, or 192 kHz Quad Wire. Therefore, the RANGE button must be used to set the sample rate range manually.

In the case of Double Wire, in spite of the AES clock being in Single Speed, the effective sample rate is Double Speed, i.e. 88.2 kHz or 96 kHz. The SRC will know when being manually configured to RANGE DS.

In the case of Quad Wire, in spite of the AES clock being in Single Speed, the effective sample rate is Quad Speed, i.e. 176.4 kHz or 192 kHz. The SRC will know when being manually configured to RANGE QS.

When the SRC RANGE is kept pressed, both LEDs DS and QS will light up. In INPUT MONITOR the LEDs DS and QS of the AES inputs will light up as well. With this the SRC signals that now any input signal is accepted. Single, Double and Quad Speed can be attached to the four AES inputs in any combination, and converted to any desired output frequency. In this **Multi-range** mode (see above) neither Double nor Quad Wire are supported as input signal.

#### **ADAT**

ADAT is restricted to a frequency range from 32 kHz up to 48 kHz. Unfortunately the signalling of doubled sample rate by sample multiplexing (S/MUX) is insufficiently standardised, and is even set falsely from several devices. Therefore such signalling is displayed by the LED DW in the INPUT MONITOR section, but does not cause any configuration change.

An ADAT input signal of 48 kHz could effectively be 48 kHz (no RANGE LED), 96 kHz S/MUX (LED RANGE DS) or 192 kHz S/MUX4 (RANGE LED QS). Therefore, the range has to be configured manually.



---

## TDIF

After a HiFS addition to the TDIF-1 specification, and the introduction of Tascam's DA98HR, the TDIF format officially supports up to 192 kHz. Even before that, the Double Wire and Quad Wire methods could be used for the same purpose. In fact Double Wire is identical to the sample multiplexing of HiFS. Apart from the DA98HR, practically no device with TDIF interface supports more than 48 kHz. Therefore the ADI-192 DD does not use the - partially incompatible - HiFS method, but instead uses the more common and 100% compatible methods Double Wire and Quad Wire to realize higher sample rates.

A TDIF input signal of 48 kHz could effectively be 48 kHz (no RANGE LED), 96 kHz in Double Wire (LED RANGE DS) or 192 kHz in Quad Wire format (RANGE LED QS). Therefore, the range has to be configured manually.

## 8.3 Clock Decoupling using the SRC

Master-slave problems occur at the latest with the use of a digital mixer. For 'normal' use of CD-player, DAT and hard disk recording, the tasks are clearly defined. The device playing back is the master in each case, the recording device the slave. The CD-player delivers the clock and the DAT synchronizes to it.

When working with a digital mixer, the CD-player would be the master and the mixer the slave. This model breaks down with a single stroke, if a DAT is also being connected, which is not recording, but also playing back. Every digital device can only synchronize to one source, the audio data of the other sources is processed with errors due to missing synchronization. Clicks and drop outs are the consequence.

Normally, the mixing console works as master and delivers a reference signal (word clock) to all other devices. But this is only possible, if the other devices have a sync input, i. e. are capable of being slaved. In a studio with digital tape machine, digital effects and hard disk recording, common CD-players and DATs cannot be connected to the mix section of the console, simply because they cannot be synchronized.

This is no problem, if a sample rate converter is being used. It synchronizes any input signal to the desired sampling rate, re. the desired clock reference.

By this, any device can be connected via the ADI-192 DD to any other device in a studio with a central clock, independent from its original capabilities. Instead of the CD-player or the DAT, the ADI-192 DD is the slave now.

## 8.4 The SRC as Signal Conditioner

DAT tapes often show little formatting errors between the various recorded takes. There can also be tiny snippets with other sample rates between the recordings. An SRC converts this patch-work reliably into a continuous permanently valid data stream with a fixed sample rate. Even if there are unformatted spots on the tape, or the DAT is being stopped or switched off, the ADI-192 DD delivers a constant signal (which does of course not contain audio information in this case).

The use as supplier of an uninterrupted data stream is also helpful for applications that would otherwise suffer from functional errors or automatic switch-off of devices. Thanks to the SRC, the ADI-192 DD always delivers a constant output clock, no matter if the inputs are not being used at the moment, are just being connected or have been used all the time.

---

## 9. Word Clock

### 9.1 Word Clock Input and Output

#### Input

The transformer isolated word clock input of the ADI-192 DD is active when WCK has been selected in the CLOCK SECTION. The signal at the BNC input can be Single, Double or Quad Speed, the ADI-192 DD automatically adapts to it. As soon as a valid signal is detected, the WCK LED is lit, else it flashes.

Thanks to RME's *Signal Adaptation Circuit*, the word clock input still works correctly even with heavily mis-shaped, dc-prone, too small or overshoot-prone signals. Thanks to automatic signal centering, 300 mV (0.3V) input level is sufficient in principle. An additional hysteresis reduces sensitivity to 1.0 V, so that over- and undershoots and high frequency disturbances don't cause a wrong trigger.

The word clock input is shipped as high impedance type (not terminated). A push switch allows to activate internal termination (75 Ohms). The switch is found on the back beside the word clock input socket. Use a small pencil or similar and carefully push the blue switch so that it snaps into its lock position. The yellow LED will be lit when termination is active. Another push will release it again and de-activate the termination.



#### Output STD

The word clock output of the ADI-192 DD is constantly active, providing the current sample frequency as word clock signal. In master mode the word clock will be fixed to 44.1 kHz or 48 kHz (DS x 2, QS x 4). In any other case the sample rate is identical to the one present at the currently chosen clock input. When the current word clock source fails, the last valid sample rate will be held automatically.

The received word clock signal can be distributed to other devices by using the word clock output. With this the usual T-adapter can be avoided, and the ADI-192 DD operates as *Signal Refresher*. This kind of operation is highly recommended, because

- input and output are phase-locked and in phase (0°) to each other
- SteadyClock removes nearly all jitter from the input signal
- the exceptional input (1 Vpp sensitivity instead of the usual 2.5 Vpp, dc cut, Signal Adaptation Circuit) plus SteadyClock guarantee a secure function even with highly critical word clock signals

Thanks to a low impedance, but short circuit proof output, the ADI-192 DD delivers 4 Vpp to 75 Ohms. For wrong termination with 2 x 75 Ohms (37.5 Ohms), there are still 3.3 Vpp at the output.

#### Output TDIF

The signal at the BNC socket labelled TDIF is identical to the signal STD, except for two differences. First it has a phase shift of 90°, necessary for TDIF interfacing. Second the word clock output TDIF always operates in Single Speed mode - as does the TDIF interface. So at 96 kHz and 192 kHz the output will provide a 48 kHz signal.

---

## 9.2 Technical Description and Background

In the analog domain one can connect any device to another device, synchronisation is not necessary. Digital audio is different. It uses a clock, the sample frequency. The signal can only be processed and transmitted when all participating devices share the same clock. If not, the signal will suffer from wrong samples, distortion, crackle sounds and drop outs.

AES/EBU, SPDIF, ADAT and MADI are self-clocking (seen from a non-technical view TDIF too, as word clock is embedded inside the TDIF cable), an additional word clock connection in principle isn't necessary. But when using more than one device simultaneously problems are likely to happen. For example any self-clocking will not work in a loop cabling, when there is no 'master' (main clock) inside the loop. Additionally the clock of all participating devices has to be synchronous. This is often impossible with devices limited to playback, for example CD players. Finally there are 'problematic' devices, which are nearly un-usable without a word clock attached anyway.

In digital studios, synchronization requirements can be met by connecting all devices to a central sync source. For instance, the master device could be a mixing desk, sending a reference signal - word clock - to all other devices. However, this will only work if all the other devices have word clock or sync inputs (e.g. some professional CD-players), allowing them to run as slaves. This being the case, all devices will receive the same clock signal, so there is no fundamental reason for sync problems when they are connected together.



*Remember that a digital system can only have one master! If the ADI-192 DD's clock mode is set to 'Master', all other devices must be set to 'Slave'.*

But word clock is not only the 'great problem solver', it also has some disadvantages. The word clock is based on a fraction of the really needed clock. For example SPDIF: 44.1 kHz word clock (a simple square wave signal) has to be multiplied by 256 inside the device using a special PLL to about 11.2 MHz. This signal then replaces the one from the quartz crystal. Big disadvantage: because of the high multiplication factor the reconstructed clock will have great deviations called jitter. The jitter of a word clock is typically many times higher compared to a quartz based clock.

The end of these problems should have been the so called Superclock, which uses 256 times the word clock frequency. This equals the internal quartz frequency, so no PLL for multiplying is needed and the clock can be used directly. But reality was different, the Superclock proved to be much more critical than word clock. A square wave signal of 11 MHz distributed to several devices - this simply means to fight with high frequency technology. Reflections, cable quality, capacitive loads - at 44.1 kHz these factors may be ignored, at 11 MHz they are the end of the clock network. Additionally it was found that a PLL not only generates jitter, but also rejects disturbances. The slow PLL works like a filter for induced and modulated frequencies above several kHz. As the Superclock is used without any filtering such a kind of jitter and noise suppression is missing.

The actual end of these problems is offered by the **SteadyClock** technology of the ADI-192 DD. Combining the advantages of modern and fastest digital technology with analog filter techniques, re-gaining a low jitter clock signal of 22 MHz from a slow word clock of 44.1 kHz is no problem anymore. Additionally, jitter on the input signal is highly rejected, so that even in real world usage the re-gained clock signal is of highest quality.

The usage of word clock with ADAT optical is critical too. The ADI-192 DD always uses a Bit-clock PLL, no matter if the clock reference is word clock or ADAT. Thanks to its very fine resolution this exceptional circuit is able to follow the complete vari-speed range of the ADAT recorder without losing a sample. Many other devices use a much coarser word clock PLL to track the ADAT input. When changing the sample rate (speed) fast, some bits are already sampled invalidly before the frequency is corrected. Drop outs and crackling will be the audible result.

---

The TDIF format is especially critical with respect to word clock. We have mentioned this in different places of this manual:

When the ADI-192 DD is slave no additional word clock connection is necessary. In case DA88 and/or DA38 are slave the word clock output TDIF of the ADI-192 DD has to be connected to the word clock input of the first (master) recorder. When using more than one recorder a special sync cable (Tascam part number PW-88S) is needed.

### 9.3 Cabling and Termination

Word clock signals are usually distributed in the form of a network, split with BNC T-adapters and terminated with resistors. We recommend using off-the-shelf BNC cables to connect all devices, as this type of cable is used for most computer networks. You will find all the necessary components (T-adapters, terminators, cables) in most electronics and/or computer stores. The latter usually carries 50 Ohm components. The 75 Ohm components used for word clock are part of video technology (RG59).

Ideally, the word clock signal is a 5 Volt square wave with the frequency of the sample rate, of which the harmonics go up to far above 500 kHz. To avoid voltage loss and reflections, both the cable itself and the terminating resistor at the end of the chain should have an impedance of 75 Ohm. If the voltage is too low, synchronization will fail. High frequency reflection effects can cause both jitter and sync failure.

Unfortunately there are still many devices on the market, even newer digital mixing consoles, which are supplied with a word clock output that can only be called unsatisfactory. If the output breaks down to 3 Volts when terminating with 75 Ohms, you have to take into account that a device, of which the input only works from 2.8 Volts and above, does not function correctly already after 3 meter cable length. So it is not astonishing that because of the higher voltage, word clock networks are in some cases more stable and reliable if cables are not terminated at all.

Ideally all outputs of word clock delivering devices are designed as low impedance types, but all word clock inputs as high impedance types, in order to not weaken the signal on the chain. But there are also negative examples, when the 75 Ohms are built into the device and cannot be switched off. In this case the network load is often 2 x 75 Ohms, and the user is forced to buy a special word clock distributor. Note that such a device is generally recommended for larger studios.

The ADI-192 DD's word clock input can be high-impedance or terminated internally, ensuring maximum flexibility. If termination is necessary (e.g. because the ADI-192 DD is the last device in the chain), push the switch at the back beside the BNC socket (see chapter 9.1).

In case the ADI-192 DD resides within a chain of devices receiving word clock, plug a T-adapter into its BNC input jack, and the cable supplying the word clock signal to one end of the adapter. Connect the free end to the next device in the chain via a further BNC cable. The last device in the chain should be terminated using another T-adapter and a 75 Ohm resistor (available as short BNC plug). Of course devices with internal termination do not need T-adaptor and terminator plug.



*Due to the outstanding SteadyClock technology of the ADI-192 DD, we recommend not to pass the input signal via T-adapter, but to use the ADI's word clock output instead. Thanks to SteadyClock, the input signal will both be freed from jitter and - in case of loss or drop out - be reset to a valid frequency.*

---

## User's Guide



# ADI-192 DD

▶ **Technical Reference**

---

## 10. Technical Specifications

### 10.1 Inputs

#### AES/EBU

- 4 x XLR, transformer balanced, ground-free, according to AES3-1992
- High-sensitivity input stage (< 0.3 Vpp)
- SPDIF compatible (IEC 60958)
- Accepts Consumer and Professional format, copy protection will be ignored
- Single Wire: 4 x 2 channels 24 bit, up to 192 kHz
- Double Wire: 4 x 2 channels 24 bit 96 kHz, equalling 4 channels 192 kHz
- Double Wire: 4 x 2 channels 24 bit 48 kHz, equalling 2 channels 192 kHz
- Quad Wire: 4 x 2 channels 24 bit 48 kHz, equalling 2 channels 192 kHz
- Lock range: 28 kHz - 104 kHz, 162 kHz - 204 kHz
- Jitter when synced to input signal: < 1 ns
- Jitter suppression: > 30 dB (2.4 kHz)

#### SPDIF (Front)

- as AES/EBU, but connected via TOSLINK
- Auto Input Detection: replaces AES input channels 1/2

#### ADAT Optical

- 2 x TOSLINK, according to Alesis specification
- Standard: 8 channels 24 bit, up to 48 kHz
- S/MUX: 2 x 8 channels 24 bit / 48 kHz, equalling 8 channels 24 bit 96 kHz
- S/MUX4: 2 x 8 channels 24 bit / 48 kHz, equalling 4 channels 24 bit 192 kHz
- Bitclock PLL ensures perfect synchronisation even in varispeed operation
- Lock range: 28 kHz – 54 kHz
- Jitter when synced to input signal: < 1 ns
- Jitter suppression: > 30 dB (2.4 kHz)

#### TDIF

- 2 x D-sub 25 pin, according to TDIF-1
- Standard: 8 channels 24 bit, up to 48 kHz
- Double Wire: 2 x 8 channels 24 bit / 48 kHz, equalling 8 channels 24 bit 96 kHz
- Quad Wire: 2 x 8 channels 24 bit / 48 kHz, equalling 4 channels 24 bit 192 kHz
- Lock range: 30 kHz – 54 kHz
- Jitter when synced to input signal: < 1 ns
- Jitter suppression: > 30 dB (2.4 kHz)

#### Word Clock

- BNC, not terminated (10 kOhm)
- Switch for internal termination 75 Ohm
- Automatic Double/Quad Speed detection and internal conversion to Single Speed
- SteadyClock guarantees super low jitter synchronization even in varispeed operation
- Transformer coupled, galvanically isolated input
- Not affected by DC-offsets within the network
- Signal Adaptation Circuit: signal refresh through auto-center and hysteresis
- Overvoltage protection
- Level range: 1.0 Vpp – 5.6 Vpp
- Lock range: 28 kHz – 220 kHz
- Jitter when synced to input signal: < 1 ns
- Jitter suppression: > 30 dB (2.4 kHz)

---

## 10.2 Outputs

### AES/EBU

- 4 x XLR, transformer balanced, ground-free, according to AES3-1992
- Output voltage Professional 4.5 Vpp, Consumer 2.1 Vpp
- Format Professional according to AES3-1992 Amendment 4
- Format Consumer (SPDIF) according to IEC 60958
- Single Wire: 4 x 2 channels 24 bit, up to 192 kHz
- Double Wire: 4 x 2 channels 24 bit 96 kHz, equalling 4 channels 192 kHz
- Double Wire: 4 x 2 channels 24 bit 48 kHz, equalling 4 channels 96 kHz
- Quad Wire: 4 x 2 channels 24 bit 48 kHz, equalling 2 channels 192 kHz

### SPDIF (Front)

- as AES/EBU, but connected via TOSLINK
- Format Consumer (SPDIF) according to IEC 60958
- Audio signal from AES/EBU channels 1/2

### ADAT Optical

- 2 x TOSLINK
- Standard: 8 channels 24 bit, up to 48 kHz
- S/MUX: 2 x 8 channels 24 bit / 48 kHz, equalling 8 channels 24 bit 96 kHz
- S/MUX4: 2 x 8 channels 24 bit / 48 kHz, equalling 4 channels 24 bit 192 kHz

### TDIF

- 2 x D-sub 25 pin, according to TDIF-1
- Standard: 8 channels 24 bit, up to 48 kHz
- Double Wire: 2 x 8 channels 24 bit / 48 kHz, equalling 8 channels 24 bit 96 kHz
- Quad Wire: 2 x 8 channels 24 bit / 48 kHz, equalling 4 channels 24 bit 192 kHz

### Word Clock

- BNC
- Max. output voltage: 5 Vpp
- Output voltage @ 75 Ohm: 4.0 Vpp
- Impedance: 10 Ohm
- Frequency range STD: 28 kHz – 220 kHz
- Frequency range TDIF: 28 kHz – 54 kHz

## 10.3 Digital

- Clocks: Internal, AES/EBU In, ADAT In, Word In, TOSLINK In, TDIF In
- Internal sample rates: 44.1 / 48 / 88.2 / 96 / 176.4 / 192 kHz
- Low Jitter Design: < 1 ns in PLL mode, all inputs
- Internal clock: 800 ps Jitter, Random Spread Spectrum
- Jitter suppression of external clocks: > 30 dB (2.4 kHz)
- PLL ensures zero dropout, even at more than 100 ns jitter
- Digital Bitclock PLL for trouble-free varispeed ADAT operation
- Group delay: typically 3 samples

---

## 10.4 Sample Rate Converter

- Self adjusting, high order aliasing filter (-144 dB)
- Resolution: 24 bit
- Dynamic Range: 140 dB RMS unweighted, 143 dBA
- Distortion (THD+N): -140 dB
- I/O ratio > 1:7 / 7:1
- Input / Output sample rate range: 28 kHz - 204 kHz
- Supports varispeed operation through fast tracking
- Group delay: 141 samples (3.2 ms @ 44.1 kHz)

## 10.5 General

- Power supply: Internal switching PSU, 100 - 240 V AC, 20 Watt
- Typical power consumption: 6 Watt
- Dimensions including rack ears (WxHxD): 483 x 44 x 242 mm (19" x 1.73" x 9.5")
- Dimensions without rack ears/handles (WxHxD): 436 x 44 x 235 mm (17.2" x 1.73" x 9.3")
- Weight: 2 kg ( 4.4 lbs)
- Temperature range: +5° up to +50° Celsius (41° F up to 122°F)
- Relative humidity: < 75%, non condensing

## 10.6 Connector Pinouts

### D-Sub TDIF-1

The 25 pin D-sub connectors are wired according to TDIF-1, version 1.1:

| Signal | Out 1/2 | Out 3/4 | Out 5/6 | Out 7/8 | Out LRCK | Out EMPH | Out FS0 | Out FS1 |
|--------|---------|---------|---------|---------|----------|----------|---------|---------|
| D-sub  | 1       | 2       | 3       | 4       | 5        | 18       | 6       | 19      |

| Signal | In FS1 | In FS0 | In EMPH | In LRCK | In 7/8 | In 5/6 | In 3/4 | In 1/2 |
|--------|--------|--------|---------|---------|--------|--------|--------|--------|
| D-sub  | 20     | 8      | 21      | 9       | 10     | 11     | 12     | 13     |

GND is connected to pins 7, 14, 15, 16, 17, 22, 23, 24, 25.

### AES/EBU

The XLR connectors are wired according to AES3-1992:

- 1 = GND (shield)
- 2 = Signal
- 3 = Signal

AES/EBU and SPDIF are biphasic modulated signals, therefore polarity doesn't matter. Pins 2 and 3 are neither hot nor cold, they carry the same signal. But as AES3 uses a balanced transmission they are inverted in polarity.



---

## 10.7 Firmware

The ADI-192 DD's main part has been realized using programmable logic. By exchanging a little component called EPROM, both function and behaviour of the unit can be changed at any time.

At the time of writing this manual, the unit is shipped with firmware 2.2. The firmware version is displayed after power on by the SYNC and LEVEL LEDs of the INPUT MONITOR for about one second.

Firmware 1.1: First firmware for the ADI-192 DD.

The current firmware 2.2 includes no bug fixes. Therefore owners of an ADI-192 DD with earlier firmware will have to accept costs for an update to version 2.2. However these costs are limited to material and work time (EPROM, flashing the EPROM, shipping).

### Changes in firmware 1.2

1. The three sections OUTPUT now have a fourth setting, OFF. In this state no LED is lit. The corresponding output provides an empty frame signal of the current sample rate. The option to switch off specific outputs provides an even better overview to the user interface of the ADI-192 DD, as unused outputs no longer emit light signals.

2. The SOURCE LEDs of the three OUTPUT sections no longer light up constantly, but depending on the LOCK state. So when selecting an input without present input signal, the corresponding LED in the OUTPUT section flashes in the same way as the ones in the SRC and CLOCK SECTION. This change unifies the user interface of the ADI-192 DD and improves overview, because invalid inputs will be recognized in any part of the user interface immediately.

3. The AES Sync display in the INPUT MONITOR section has been extended. In case multiple AES signals with different ranges (Single, Double or Quad) are attached simultaneously and are synchronous as well, flashing LEDs will indicate that these signals are still invalid for the currently chosen SRC mode.

4. New function **SRC Multi-range**. Keep the button SRC RANGE pressed and both LEDs DS and QS will light up. In INPUT MONITOR the LEDs DS and QS of the AES inputs will light up as well. With this the SRC signals that now any input signal is accepted. Single, Double and Quad Speed can be attached to the four AES inputs in any combination, and converted to any desired output frequency. In this mode neither Double nor Quad Wire are supported as input signal.

Note: With firmware 1.2 the SRC LEDs of the OUTPUT sections have been changed from red to blue. Unfortunately the orange QS LEDs were nearly identical to the red SRC LEDs. The changed colour helps to notice an active SRC mode.

### Changes in firmware 2.2

1. More sensitive mute for TDIF when encountering clock problems. Prevents noise in certain situations with invalid clock. (v 2.1)

2. New function Follow Clock for automated CLOCK STATE switching.

---

## 11. Technical Background

### 11.1 Terminology

#### Single Speed

Sample rate range originally used in Digital Audio. Typical applications are 32 kHz (digital radio broadcast), 44.1 kHz (CD), and 48 kHz (DAT).

#### Double Speed

Doubles the original sample rate range, in order to achieve higher audio quality and improved audio processing. 64 kHz is practically never used, 88.2 kHz is quite rare in spite of certain advantages. 96 kHz is a common format. Sometimes called **Double Fast**.

#### Quad Speed

Controversially discussed way of ensuring hi-end audio quality and processing by quadrupling the sample frequency. 128 kHz is non-existent, 176.4 kHz is rare, if at all then 192 kHz is used, e.g. for DVD Audio.

#### Single Wire

Standard audio data transfer, where the audio signal's sample rate is equal to the rate of the digital signal. Used from 32 to 192 kHz. Sometimes called **Single Wide**.

#### Double Wire

Before 1998 there were no receiver/transmitter circuits available that could receive or transmit more than 48 kHz. Higher sample rates were transferred by splitting odd and even bits across the L/R channels of a single AES connection. This provides for twice the data rate, and hence twice the sample rate. A stereo signal subsequently requires two AES/EBU ports. See chapter 11.3.

The Double Wire method is an industry standard today, however it has a number of different names, like **Dual AES**, **Double Wide**, **Dual Line** and **Wide Wire**. The AES3 specification uses the uncommon term *Single channel double sampling frequency mode*. When used with the ADAT format, the term S/MUX is commonly used.

Double Wire not only works with Single Speed signals, but also with Double Speed. As an example, Pro Tools HD, whose AES receiver/transmitter only work up to 96 kHz, uses Double Wire to transmit 192 kHz. Four channels of 96 kHz turn into two channels of 192 kHz.

#### Quad Wire

Similar to Double Wire, with samples of one channel spread across four channels. This way single speed devices can transmit up to 192 kHz, but need two AES/EBU ports to transmit one channel. Also called **Quad AES**.

#### S/MUX

Since the ADAT hardware interface is limited to Single Speed, the Double Wire method is used for sample rates up to 96 kHz, but usually referred to as S/MUX (Sample Multiplexing). An ADAT port supports four channels this way. The distribution of the samples is described in chapter 11.3.

#### S/MUX4

The Quad Wire method allows to transmit two channels at up to 192 kHz via ADAT. The method is referred to as S/MUX4. The distribution of the samples is described in chapter 11.4.

Note: All conversions of the described methods are lossless. The existing samples are just spread or re-united between the channels.

---

## 11.2 Lock, SyncCheck and SyncAlign

Digital signals consist of a carrier and the data. If a digital signal is applied to an input, the receiver has to synchronize to the carrier clock in order to read the data correctly. To achieve this, the receiver uses a PLL (Phase Locked Loop). As soon as the receiver meets the exact frequency of the incoming signal, it is locked. This **Lock** state remains even with small changes of the frequency, because the PLL tracks the receiver's frequency.

If an AES, TDIF or ADAT signal is applied to the ADI-192 DD, the corresponding SYNC LED starts flashing. The unit indicates LOCK, i. e. a valid input signal (in case the signal is also in sync, the LED is constantly lit, see below).

Unfortunately, LOCK does not necessarily mean that the received signal is correct with respect to the clock which processes the read out of the embedded data. Example [1]: The ADI-192 DD is set to 44.1 kHz internal clock, and a CD-Player is connected to input AES1. The corresponding LED will start flashing immediately, but the CD-Player's sample rate is generated internally, and thus slightly higher or lower than the ADI-192 DD's internal sample rate. Result: When reading out the data, there will frequently be read errors that cause clicks and drop outs.

Also when using multiple inputs, a simple LOCK is not sufficient. The above described problem can be solved elegantly by setting the ADI-192 DD from internal clock to AES (its internal clock will then be the clock delivered by the CD-Player). But in case a DAT recorder is connected as a second source, there will again be a slight difference in the sample rate, and therefore clicks and drop outs [2]. Another example could be connecting two ADAT machines which are not synchronous to each other due to wrong clock setup [3].

In order to display those problems optically at the device, the ADI-192 DD includes **SyncCheck**. It checks all clocks used for *synchronicity*. If they are not synchronous to each other (i. e. absolutely identical), the SYNC LED of the asynchronous input flashes. In example 1 it would have been obvious that the SOURCE AES LED kept on flashing after connecting the CD-Player. In example 2, SYNC AES1 would be constantly lit, but the SYNC LED of the input used by the DAT would be flashing. In example 3, again one LED would be constantly lit, while the other one keeps on flashing.

In practice, SyncCheck allows for a quick overview of the correct configuration of all digital devices. This way one of the most difficult and error-prone topics of the digital studio world finally becomes easy to handle.

A special problem occurs with devices offering several AES or SPDIF inputs. While with ADAT and TDIF all eight channels share the same clock base, with AES there are several completely independent receivers with their own PLLs and data buffers. Therefore there can be a random error of  $\pm 1$  sample difference between the stereo pairs. The ADI-192 DD's exclusive **SyncAlign** technology avoids this effect and guarantees sample synchronicity among all four stereo channels.

---

### 11.3 DS - Double Speed

When activating the *Double Speed* mode the ADI-192 DD operates at double sample rate. The internal clock 44.1 kHz turns to 88.2 kHz, 48 kHz to 96 kHz. The internal resolution is still 24 bit.

Sample rates above 48 kHz were not always taken for granted, and are still not widely used because of the CD format (44.1 kHz) dominating everything. Before 1998 there were no receiver/transmitter circuits available that could receive or transmit more than 48 kHz. Therefore a work-around was used: instead of two channels, one AES line only carries one channel, whose odd and even samples are being distributed to the former left and right channels. By this, you get the double amount of data, i. e. also double sample rate. Of course in order to transmit a stereo signal two AES/EBU ports are necessary then.

This transmission mode is called *Double Wire* in the professional studio world, and is also known as *S/MUX* (abbreviation for *Sample Multiplexing*) in connection with the ADAT format. The AES3 specification uses the uncommon term *Single channel double sampling frequency mode*.

Not before February 1998, Crystal shipped the first 'single wire' receiver/transmitters that could also work with double sample rate. It was then possible to transmit two channels of 96 kHz data via one AES/EBU port.

But *Double Wire* is still far from being dead. On one hand, there are still many devices which can't handle more than 48 kHz, e. g. digital tape recorders. But also other and newer interfaces like ADAT or TDIF are still using this technique. And finally it can be used to transfer 192 kHz using 96 kHz-capable equipment.

Since the ADAT and TDIF interface are not defined to operate beyond 48 kHz directly, the ADI-192 DD uses sample multiplexing in DS operation. One channel's data is distributed to two channels according to the following table:

| Original  | 1    | 2    | 3    | 4    | 5   | 6   | 7   | 8   |
|-----------|------|------|------|------|-----|-----|-----|-----|
| DS Signal | 1/2  | 3/4  | 5/6  | 7/8  | 1/2 | 3/4 | 5/6 | 7/8 |
| Port      | MAIN | MAIN | MAIN | MAIN | AUX | AUX | AUX | AUX |

As the transmission of double rate signals is done at standard sample rate (Single Speed), the ADAT and TDIF ports still operate at 44.1 kHz or 48 kHz.

The 'Double Wire' or 'S/MUX' technology of the AD-192 DD's TDIF interface allows a recording with up to 96 kHz at halved track numbers with any (!) DTRS device, and is fully compatible to Tascams DA98HR.

### 11.4 QS – Quad Speed

Due to the small number of available devices that use sample rates up to 192 kHz, but even more due to a missing real world application (CD...), Quad Speed has had no broad success so far. An implementation of the ADAT format as double S/MUX (S/MUX4) results in only two channels per ADAT port.

In earlier times the transmission of 192 kHz had not been possible via Single Wire, so once again sample multiplexing was used: instead of two channels, one AES line transmits only one half of a channel. A transmission of one channel requires two AES/EBU lines, stereo requires even four. This transmission mode is being called *Quad Wire* in the professional studio world, and is also known as *S/MUX4* in connection with the ADAT format. The AES3 specification does not mention Quad Wire.

In QS operation, the ADI-192 DD spreads two channel's data on all 8 channels of an ADAT and TDIF port according to the following table:

| Original       | 1           |             | 2           |             | 3          |            | 4          |            |
|----------------|-------------|-------------|-------------|-------------|------------|------------|------------|------------|
| DS Signal Port | 1/2<br>MAIN | 3/4<br>MAIN | 5/6<br>MAIN | 7/8<br>MAIN | 1/2<br>AUX | 3/4<br>AUX | 5/6<br>AUX | 7/8<br>AUX |

As the transmission of quad rate signals is done at standard sample rate (Single Speed), the ADAT and TDIF ports still operate at 44.1 kHz or 48 kHz.

The 'Quad Wire' or 'S/MUX4' technology of the ADI-192 DD's TDIF interface allows to transmit two channels at up to 192 kHz with every (!) DTRS device.

Unfortunately Tascam's TDIF implementation is incompatible to Quad Wire, as the samples are not transmitted in the order of 1-2-3-4, but 1-3-2-4. In case the special 192 kHz mode of the DTRS machine DA-98HR shall be used, the machine should be connected and used with the ADI-192 DD via AES.

## 11.5 AES/EBU - SPDIF

The most important electrical properties of 'AES' and 'SPDIF' can be seen in the table below. AES/EBU is the professional balanced connection using XLR plugs. The standard is being set by the *Audio Engineering Society* based on the AES3-1992. For the 'home user', SONY and Philips have omitted the balanced connection and use either Phono plugs or optical cables (TOSLINK). The format called S/P-DIF (SONY/Philips Digital Interface) is described by IEC 60958.

| Type           | AES3-1992                      | IEC 60958  |
|----------------|--------------------------------|--|
| Connection     | XLR                            | RCA / Optical                                      |
| Mode           | Balanced                       | Un-balanced  |
| Impedance      | 110 Ohm                        | 75 Ohm   |
| Level          | 0.2 V up to 5 Vss              | 0.2 V up to 0.5 Vss                                |
| Clock accuracy | not specified                  | I: $\pm 50$ ppm<br>II: 0,1%<br>III: Variable Pitch |
| Jitter         | < 0.025 UI (4.4 ns @ 44.1 kHz) | not specified                                      |

Besides the electrical differences, both formats also have a slightly different setup. The two formats are compatible in principle, because the audio information is stored in the same place in the data stream. However, there are blocks of additional information, which are different for both standards. In the table, the meaning of the first byte (#0) is shown for both formats. The first bit already determines whether the following bits should be read as Professional or Consumer information.

| Byte | Mode | Bit 0 | 1      | 2    | 3        | 4 | 5      | 6            | 7 |
|------|------|-------|--------|------|----------|---|--------|--------------|---|
| 0    | Pro  | P/C   | Audio? |      | Emphasis |   | Locked | Sample Freq. |   |
| 0    | Con  | P/C   | Audio? | Copy | Emphasis |   | Mode   |              |   |

It becomes obvious that the meaning of the following bits differs quite substantially between the two formats. If a device like a common DAT recorder only has an SPDIF input, it usually understands only this format. In most cases, it will switch off when being fed Professional-coded data. The table shows that a Professional-coded signal would lead to malfunctions for copy prohibition and emphasis, if being read as Consumer-coded data.

Nowadays many devices with SPDIF input can handle Professional subcode. Devices with AES3 input almost always accept Consumer SPDIF (passive cable adapter necessary).

---

## 11.6 Group Delay – I/O Latency

Every digital device has a specific delay time between input and output. The so called *group delay* of 3 samples for basic applications using the ADI-192 DD is quite low. However, the sample rate converter operates with digital filters, which cause significantly more delay: 141 samples referred to the input sample rate. This equals about 3 ms at 44.1 kHz.

| <b>Mode - I/O</b>                            | <b>Samples</b> |
|--|----------------|
| <b>Single Speed</b>                          |                |
| AES to AES                                   | 3              |
| AES to TDIF-TDIF to AES                      | 5              |
| AES to ADAT - ADAT to AES                    | 6              |
| TDIF to TDIF                                 | 2              |
| ADAT to ADAT                                 | 3              |
| ADAT to TDIF - TDIF to ADAT                  | 5              |
| ADAT to TDIF - TDIF to AES - AES to ADAT     | 8              |
| <br>   |                |
| AES to AES with SRC                          | 144            |
| <br>   |                |
| <b>Double Speed</b>                          |                |
| AES to AES                                   | 5              |
| AES to TDIF - TDIF to AES                    | 9              |
| AES to ADAT - ADAT to AES                    | 11             |
| TDIF to TDIF                                 | 4              |
| ADAT to ADAT                                 | 6              |
| ADAT to TDIF - TDIF to ADAT                  | 10             |
| ADAT to TDIF - TDIF to AES - AES to ADAT     | 16             |
| <br>   |                |
| AES to AES with SRC                          | 147            |
| <br>   |                |
| <b>Quad Speed</b>                            |                |
| AES to AES                                   | 11             |
| AES to TDIF - TDIF to AES                    | 14             |
| AES to ADAT - ADAT to AES                    | 23             |
| TDIF to TDIF                                 | 8              |
| ADAT to ADAT                                 | 12             |
| ADAT to TDIF - TDIF to ADAT                  | 20             |
| AES to TDIF - TDIF to ADAT - ADAT to AES     | 31             |
| <br>   |                |
| AES to AES with SRC                          | 153            |
| <br>   |                |
| <b>Sample Multiplexing</b>                   |                |
| AES Double Wire to Single Wire or vice versa | +1             |
| AES Quad Wire to Single Wire or vice versa   | +1             |

## 11.7 SteadyClock

The SteadyClock technology of the ADI-192 DD guarantees an excellent performance in all clock modes. Its highly efficient jitter suppression refreshes and cleans up any clock signal, and provides it as reference clock at the word clock output.

Usually a clock section consists of an analog PLL for external synchronization and several quartz oscillators for internal synchronisation. SteadyClock requires only one quartz, using a frequency not equalling digital audio. Latest circuit designs like hi-speed digital synthesizer, digital PLL, 100 MHz sample rate and analog filtering allow RME to realize a completely newly developed clock technology, right within the FPGA at lowest costs. The clock's performance exceeds even professional expectations. Despite its remarkable features, SteadyClock reacts quite fast compared to other techniques. It locks in fractions of a second to the input signal, follows even extreme varipitch changes with phase accuracy, and locks directly within a range of 28 kHz up to 220 kHz.

SteadyClock has originally been developed to gain a stable and clean clock from the heavily jittery MADI data signal. The embedded MADI clock suffers from about 80 ns jitter, caused by the time resolution of 125 MHz within the format. Common real-world interface jitter values are below 10 ns, while a very good value is less than 2 ns.

The picture to the right shows the MADI input signal with 80 ns of jitter (top graph, yellow). Thanks to SteadyClock this signal turns into a clock with less than 2 ns jitter (lower graph, blue).

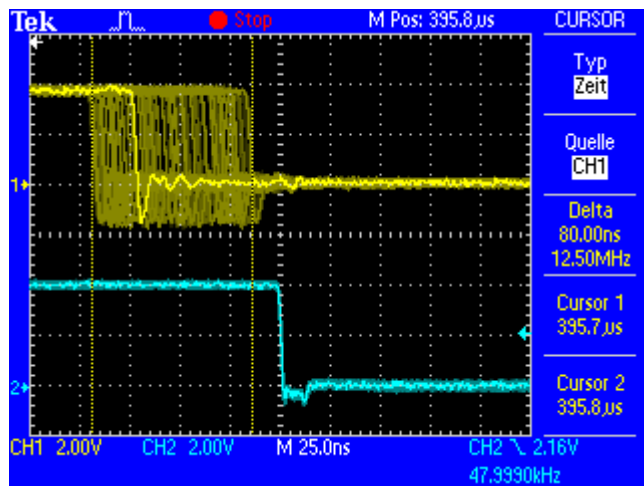

Using the input sources of the ADI-192 DD, word clock, TDIF, ADAT and AES, you'll most probably never experience such high jitter values. But SteadyClock is not only ready for them, it would handle them just on the fly.

The screenshot to the right shows an extremely jittery word clock signal of about 50 ns jitter (top graph, yellow). Again SteadyClock provides an extreme clean-up. The filtered clock shows less than 2 ns jitter (lower graph, blue).

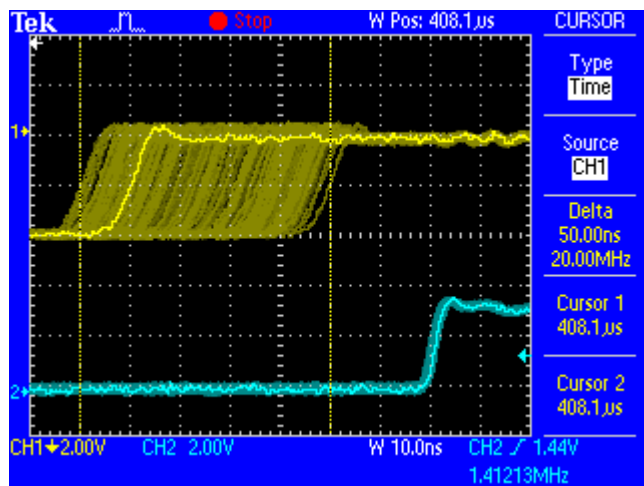

The cleaned and jitter-free signal can be used as reference clock for any application, without any problem. The signal processed by SteadyClock is of course not only used internally, but also available at the ADI-192 DD's word clock output. It is also used to clock all the digital outputs.

## 12. Block Diagram

