

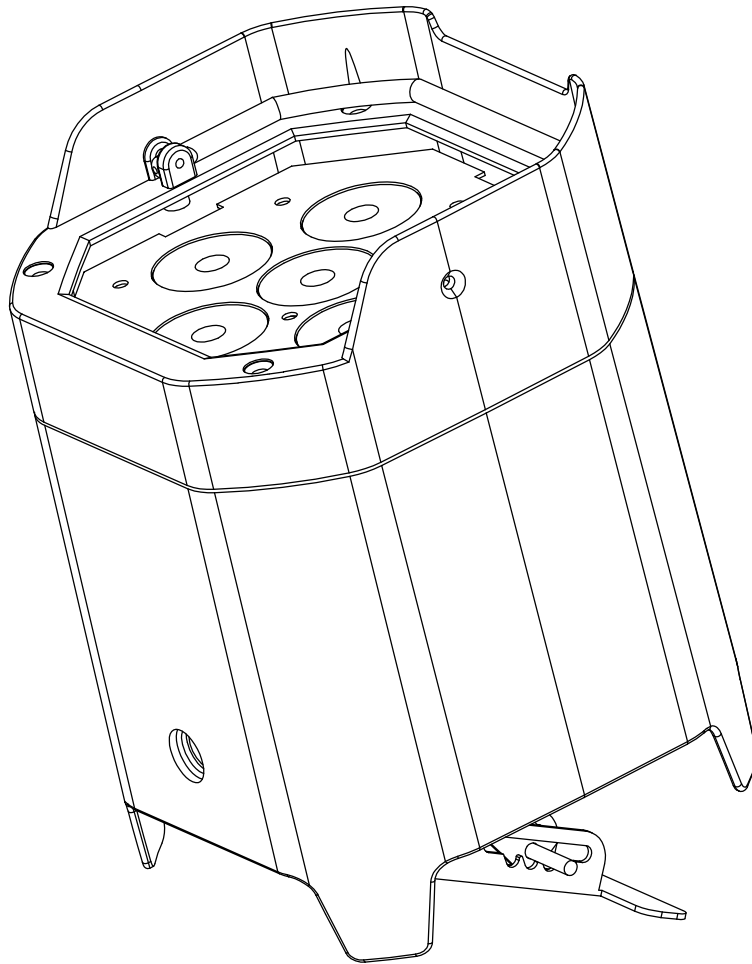

# ELEMENT QA



## *User Instructions*



©2018 ADJ Products, LLC all rights reserved. Information, specifications, diagrams, images, and instructions herein are subject to change without notice. ADJ Products, LLC logo and identifying product names and numbers herein are trademarks of ADJ Products, LLC. Copyright protection claimed includes all forms and matters of copyrightable materials and information now allowed by statutory or judicial law or hereinafter granted. Product names used in this document may be trademarks or registered trademarks of their respective companies and are hereby acknowledged. All non-ADJ Products, LLC brands and product names are trademarks or registered trademarks of their respective companies.

**ADJ Products, LLC** and all affiliated companies hereby disclaim any and all liabilities for property, equipment, building, and electrical damages, injuries to any persons, and direct or indirect economic loss associated with the use or reliance of any information contained within this document, and/or as a result of the improper, unsafe, insufficient and negligent assembly, installation, rigging, and operation of this product.

**FCC STATEMENT**

This device complies with Part 15 of the FCC Rules. Operation is subject to the following two conditions: (1) this device may not cause harmful interference, and (2) this device must accept any interference received, including interference that may cause undesired operation.

**FCC RADIO FREQUENCY INTERFERENCE WARNINGS & INSTRUCTIONS**

This product has been tested and found to comply with the limits as per Part 15 of the FCC Rules. These limits are designed to provide reasonable protection against harmful interference in a residential installation. This device uses and can radiate radio frequency energy and, if not installed and used in accordance with the included instructions, may cause harmful interference to radio communications. However, there is no guarantee that interference will not occur in a particular installation. If this device does cause harmful interference to radio or television reception, which can be determined by turning the device off and on, the user is encouraged to try to correct the interference by one or more of the following methods:

- Reorient or relocate the device.
- Increase the separation between the device and the receiver.
- Connect the device to an electrical outlet on a circuit different from which the radio receiver is connected.
- Consult the dealer or an experienced radio/TV technician for help.

**DOCUMENT VERSION**

Please check [www.adj.com](http://www.adj.com) for the latest revision/update of this guide.

Date	Document Version	Software Version ≥	DMX Channel Mode	Notes
09/11/17	1.2	1.01	4/5/6/9/10	ETL Version
11/13/18	1.4	1.07	No Change	Display Lock Added IR Remote Functions Updated
01/12/21	1.6	1.08	No Change	Updated Primary/Secondary Modes

**Europe Energy Saving Notice**

Energy Saving Matters (EuP 2009/125/EC)

Saving electric energy is a key to help protecting the environment. Please turn off all electrical products when they are not in use. To avoid power consumption in idle mode, disconnect all electrical equipment from power when not in use. Thank you!

Introduction	3
Features   Warranty Registration   Installation	4
Safety Precautions	5
Battery Precautions   Battery Status & Charging	6
Overview	8
DMX Set Up	9
DMX Addressing	11
DMX Modes	13
Color Macro Chart	16
System Menu	18
Operating Instructions	19
Primary-Secondary Set Up   WiFly Set Up	23
UC IR & Airstream Control	24
Dimmer Curve Chart	25
Dimensional Drawings   Kickstand Angles	26
Multiple Unit Power Linking   Fuse Replacement	27
Trouble Shooting   Cleaning   Optional Accessories	27
Warranty	28
Technical Specifications	29

**Unpacking:** Thank you for purchasing the Element QA by ADJ Products, LLC. Every Element QA has been thoroughly tested and has been shipped in perfect operating condition. Carefully check the shipping carton for damage that may have occurred during shipping. If the carton appears to be damaged, carefully inspect your fixture for any damage and be sure all accessories necessary to operate the unit has arrived intact. In the case damage has been found or parts are missing, please contact our toll free customer support number for further instructions. Do not return this unit to your dealer without first contacting customer support.

**Introduction:** The Element QA is a rechargeable lithium battery powered, DMX intelligent, LED par fixture with ADJ's WiFly TransCeiver with wireless DMX built-in. WiFly control and battery power give you the freedom to set up your unit where ever you wish without the restrictions of power or DMX cabling. This unit can be used in a stand alone mode or connected in a Primary-Secondary set up. This unit has five operating modes: Auto mode (color change, color fade, and color change and fade combination), RGWA Dimmer mode, Static Color mode, Sound Active mode, and DMX control mode. To optimize the performance of this product, please read these operating instructions carefully to familiarize yourself with the basic operations of this unit. These instructions contain important safety information regarding the use and maintenance of this unit. Please keep this manual with the unit, for future reference.

**Customer Support:** Contact ADJ Service for any product related service and support needs. Also visit [forums.adj.com](http://forums.adj.com) with questions, comments or suggestions.

**Parts:** To purchase parts online visit <http://parts.americandj.com>

**ADJ SERVICE USA - Monday - Friday 8:00am to 4:30pm PST**

**Voice: 800-322-6337 | Fax: 323-832-2941 | [support@adj.com](mailto:support@adj.com)**

**ADJ SERVICE EUROPE - Monday - Friday 08:30 to 17:00 CET**

**Voice: +31 45 546 85 60 | Fax: +31 45 546 85 96 | [support@adj.eu](mailto:support@adj.eu)**

### **ADJ PRODUCTS LLC USA**

6122 S. Eastern Ave. Los Angeles, CA. 90040

323-582-2650 | Fax 323-532-2941 | [www.adj.com](http://www.adj.com) | [info@adj.com](mailto:info@adj.com)

### **ADJ SUPPLY Europe B.V**

Junostraat 2 6468 EW Kerkrade, The Netherlands

+31 (0)45 546 85 00 | Fax +31 45 546 85 99

[www.adj.eu](http://www.adj.eu) | [info@americandj.eu](mailto:info@americandj.eu)

### **ADJ PRODUCTS GROUP Mexico**

AV Santa Ana 30 Parque Industrial Lerma, Lerma, Mexico 52000

+52 (728) 282-7070

**Warning!** To prevent or reduce the risk of electrical shock or fire, do not expose this unit to rain or moisture.

**Caution!** There are no user serviceable parts inside this unit. Do not attempt any repairs yourself, doing so will void your manufactures warranty. In the unlikely event your unit may require service please contact ADJ Products, LLC.

***PLEASE recycle the shipping carton when ever possible.***

## Element QA

## Features

- Five Operating Modes
- Electronic Dimming 0-100%
- RGBA Color Mixing
- 5 Selectable Dimming Curves
- 64 Color Macros
- Built in Microphone
- DMX-512 protocol
- 3-Pin DMX Connection
- 5 DMX Modes: 4 Channel Mode, 5 Channel Mode, 6 Channel Mode, 9 Channel Mode, & 10 Channel Mode
- Rechargeable Lithium Battery
- Built-In ADJ's WiFly TransCeiver Wireless DMX
- ADJ UC IR & Airstream IR compatible
- Multiple Unit Power Linking (See page 27))

### Included Accessories:

1 x I.E.C. power cable

1 x UC IR Remote Control

1 x Airstream IR Transmitter

## Element QA

## Warranty Registration

The Element QA carries a 2 year limited warranty. Please fill out the enclosed warranty card to validate your purchase. All returned service items whether under warranty or not, must be freight pre-paid and accompany a return authorization (R.A.) number. The R.A. number must be clearly written on the outside of the return package. A brief description of the problem as well as the R.A. number must also be written down on a piece of paper included in the shipping carton. If the unit is under warranty, you must provide a copy of your proof of purchase invoice. You may obtain a R.A. number by contacting our customer support team on our customer support number. All packages returned to the service department not displaying a R.A. number on the outside of the package will be returned to the shipper.

## Element QA

## Installation

The unit should be mounted using a mounting clamp (not provided), affixing it to the mounting bracket that is provided with the unit. Always ensure that the unit is firmly fixed to avoid vibration and slipping while operating. Always ensure that the structure to which you are attaching the unit is secure and is able to support a weight of 10 times the unit's weight. **ALWAYS** use safety cables that can hold 12 times the weight of the unit when installing the fixture.

This equipment must be installed by a professional, and it must be installed in a place where it is out of the reach of people's grasp.

**NOT FOR RESIDENTIAL/HOUSE HOLD USE  
NON DESTINÉ À UN USAGE DOMESTIQUE**

**SUITABLE FOR DAMP LOCATIONS  
CONVIENT AUX EMPLACEMENTS HUMIDES**

- To reduce the risk of electrical shock or fire, do not expose this unit rain or moisture
- Do not attempt to operate this unit if the power cord has been frayed or broken. Do not attempt to remove or break off the ground prong from the electrical cord. This prong is used to reduce the risk of electrical shock and fire in case of an internal short.
- Disconnect from main power before making any type of connection.
- Do not remove the cover under any conditions. There are no user serviceable parts inside.
- Never operate this unit when it's housing is removed.
- Never plug this unit in to a dimmer pack
- Always be sure to mount this unit in an area that will allow proper ventilation. Allow about 6" (15cm) between this device and a wall.
- Do not attempt to operate this unit, if it becomes damaged.
- During long periods of non-use, disconnect the unit's main power.
- Always mount this unit in safe and stable matter.
- Power supply cords should be routed so that they are not likely to be walked on or pinched by items placed upon or against them, paying particular attention to the point they exit from the unit.
- Cleaning -The fixture should be cleaned only as recommended by the manufacturer. See page 27 for cleaning details.
- Heat -The appliance should be situated away from heat sources such as radiators, heat registers, stoves, or other appliances (including amplifiers) that produce heat.
- The fixture should be serviced by qualified service personnel when:
  - A. The power-supply cord or the plug has been damaged.
  - B. The appliance does not appear to operate normally or exhibits a marked change in performance.
  - C. The fixture has fallen and/or subjected to extreme handling.

## **1. Handling of Batteries**

### **1.1 Do Not Short Circuit the Battery**

Try to never short circuit the battery. It generates a very high current which could cause the battery to overheat which may result in electrolyte gel leakage, harmful fumes, or explosion. The LIR tabs may easily short-circuit by placing them on conductive surface. A short circuit may lead to heat build up and damage of the battery. An appropriate circuitry with PCM is employed to protect accidental short circuit of the battery pack.

### **1.2 Mechanical shock**

Dropping the unit, impact hit, bending, etc. may cause failure or shortend life of the LIR battery.

## **3. Other**

### **3.1 Battery connection**

- 1). Direct soldering of wire leads or devices to the battery is strictly prohibited.
- 2). Lead tabs with pre-soldered wiring shall be spot welded to the batteries. Direct soldering may cause damage of components, such as separator and insulator, by heat build up.

### **3.2 Prevention of short circuit within a battery pack**

There is enough insulation layers between wiring and the batteries to provide extra safety protection. The battery pack is constructed in a way that no short circuit will occur which may cause smoke or fire.

### **3.3 Do No Disassemble the Batteries**

- 1). Never disassemble the batteries.  
Doing this may cause a internal short circuit in the battery, which may lead to harmful fumes, fire, explosion, or other problems.
- 2). Electrolyte Gel is harmful  
Electrolyte Gel should not leak from the LIR battery. Should the electrolyte gel come into contact with the skin or eyes, flush the area of contact immediately with fresh water and seek medical attention immediately.

### **3.4 Do Not Expose the Battery to Heat or Fire**

Never incinerate or dispose of the batteries in fire. This may cause an explosion, which would be very dangerous.

### **3.5 Do Not Expose the Battery to water or liquids**

Never soak/drop the batteries in liquids such as water, seawater, drinks such as soft drinks, juices, coffee or other.

### **3.6 Battery Replacement**

For battery replacement please contact ADJ customer support (800) 322-6337.

### **3.7 Do Not use a damaged Battery**

The battery could be damaged during shipping, caused by shock. Should the battery be found damaged, including damages to the plastic casing of the battery, deformation of the battery package, smelling of an electrolyte, or leakage of the electrolyte gel, or other, DO NOT use the battery. A battery with a odor of electrolyte or a gel leakage should be placed away from fire to avoid fire or explosion.



#### 4. Battery Storage

When storing the battery, it should be stored at room temperature, with a charge of at least 50%. We recommend that during long periods of storage that the battery be charged every 6 months. Doing this will prolong the life of the battery and will also make sure that the battery charge does not fall below the 30% mark.

#### 5. Other Chemical Reaction

Because batteries utilize a chemical reaction, battery performance will deteriorate over time even if stored for a long period of time without being used. In addition, if the various usage conditions such as charge, discharge, ambient temperature, etc. are not maintained within the specified ranges, the life expectancy of the battery maybe shortened or the device in which the battery is used may be damaged by electrolyte gel leakage. If the batteries cannot maintain a charge for long periods of time, even when they are charged correctly, this may indicate it is time to change the battery.

#### 6. Battery Disposal

Please dispose of battery according to local regulations.

#### ***Battery Status:***

This function is used to check the life status of the battery.

Plug the fixture in and press the MODE button until “**bXXX**” is displayed. “XXX” represents the current battery life. The number that is displayed is the remaining battery life. If “**b---**” is displayed, it means that you are running the unit on AC power. ***Please do not let the battery fully die, this severely shortens the life of the battery.***

***NOTE:*** When the battery life is below 30% the battery percentage will flash. At 15% power the fixture will shut off.

***NOTE:*** *When using battery power, after 20 seconds of inactivity, the display will revert back to the battery life display.*

***Battery Recharge:*** To recharge the battery, plug the supplied I.E.C. cord into the I.E.C. input on the side of the unit and plug the other end into a matching power supply. It takes about 4 hours to reach full charge (with the power off). **The display will STOP flashing when the unit reaches 100% charge.**

***Note:*** *When unplugging the unit from charging and then applying power via battery, there will be a minimal charge drop.*

For a faster recharge, turn the Load setting to “**Off**” and turn the battery “**On**”. See “**LOAD SETTING**” on page 19.



**DMX Connections and Power Connections:** All connections are located underneath the unit. You will find all connections and other features pointed out below.

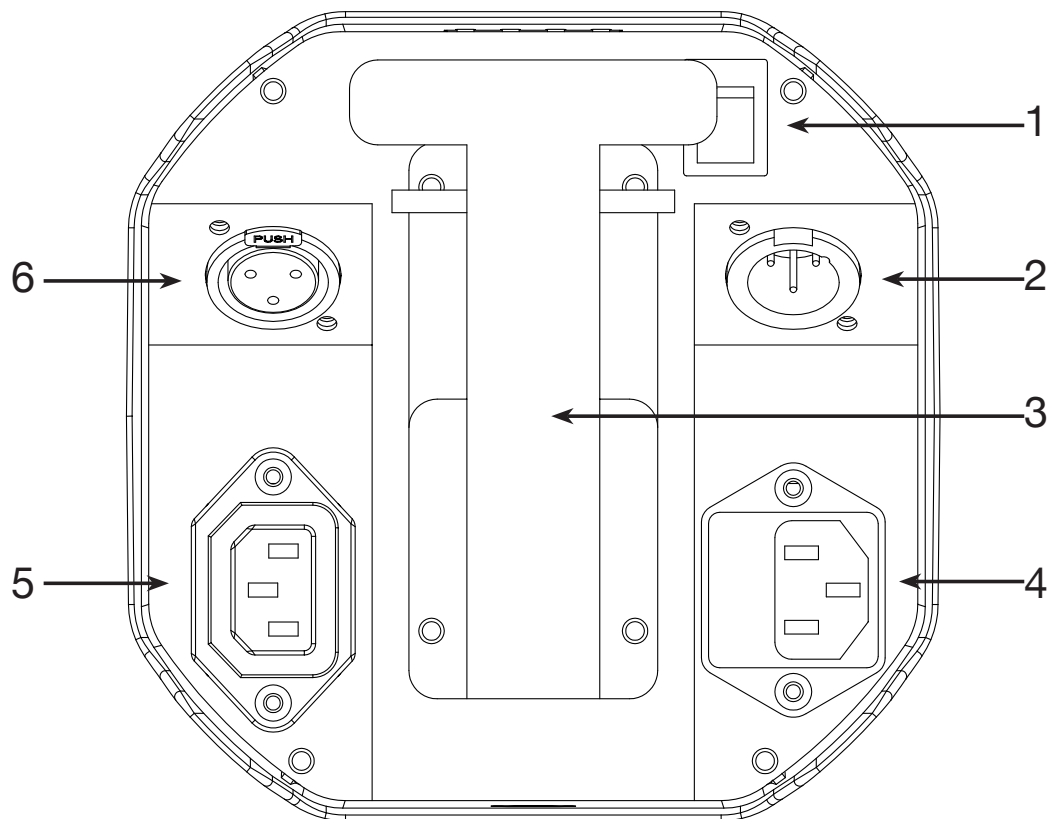

- 1. Battery On/Off Switch:** This switch is used to turn ON battery power and also turn ON the PCB output. See page 19 “**LOAD SETTING**” to activate.
- 2. 3-Pin DMX In:** This input is used to send a DMX signal to a connected unit or for primary-secondary set up.
- 3. Kickstand:** This kickstand is used to angle the unit to various degrees. There are 3 different degree levels. Note: Be very cautious at the degree in which you angle the unit at, due to the fact that it could fall over.
- 4. Power Input & Fuse Holder:** This input is used to connect the included I.E.C. power cord. After connecting the power cord, plug the other end into a matching power source. Located inside the power socket is the fuse housing. See page 27 for fuse replacement.
- 5. Power Output:** This connection is used to receive a incoming power source from another unit.
- 6. 3-Pin DMX Out:** This output is used to send a signal to a connected unit.

**DMX-512:** DMX is short for Digital Multiplex. This is a universal protocol used as a form of communication between intelligent fixtures and controllers. A DMX controller sends DMX data instructions from the controller to the fixture. DMX data is sent as serial data that travels from fixture to fixture via the DATA “IN” and DATA “OUT” XLR terminals located on all DMX fixtures (most controllers only have a DATA “OUT” terminal).

**DMX Linking:** DMX is a language allowing all makes and models of different manufactures to be linked together and operate from a single controller, as long as all fixtures and the controller are DMX compliant. To ensure proper DMX data transmission, when using several DMX fixtures try to use the shortest cable path possible. The order in which fixtures are connected in a DMX line does not influence the DMX addressing. For example; a fixture assigned a DMX address of 1 may be placed anywhere in a DMX line, at the beginning, at the end, or anywhere in the middle. When a fixture is assigned a DMX address of 1, the DMX controller knows to send DATA assigned to address 1 to that unit, no matter where it is located in the DMX chain.

**Data Cable (DMX Cable) Requirements (For DMX Operation):** The Element QA can be controlled via DMX-512 protocol. The Element QA has 5 DMX modes, please see pages 12 or 21 for the different modes. The DMX address is set on the front panel of the Element QA. Your unit and your DMX controller require a standard 3-pin XLR connector for data input and data output (Figure 1). We recommend Accu-Cable DMX cables. If you are making your own cables, be sure to use standard 110-120 Ohm shielded cable (This cable may be purchased at almost all pro lighting stores). Your cables should be made with a male and female XLR connector on either end of the cable. Also remember that DMX cable must be daisy chained and cannot be split.



Figure 1

**Notice:** Be sure to follow figures two and three when making your own cables. Do not use the ground lug on the XLR connector. Do not connect the cable’s shield conductor to the ground lug or allow the shield conductor to come in contact with the XLR’s outer casing. Grounding the shield could cause a short circuit and erratic behavior.

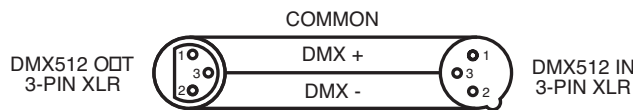

Figure 2

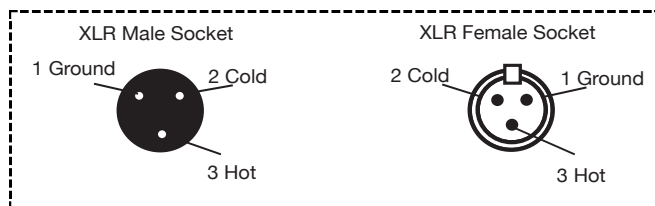
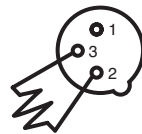

Figure 3

XLR Pin Configuration
Pin 1 = Ground
Pin 2 = Data Compliment (negative)
Pin 3 = Data True (positive)

**Special Note: Line Termination.** When longer runs of cable are used, you may need to use a terminator on the last unit to avoid erratic behavior. A terminator is a 110-120 ohm 1/4 watt resistor which is connected between pins 2 and 3 of a male XLR connector (DATA + and DATA -). This unit is inserted in the female XLR connector of the last unit in your daisy chain to terminate the line. Using a cable terminator (ADJ part number Z-DMX/T) will decrease the possibilities of erratic behavior.



Termination reduces signal errors and avoids signal transmission problems and interference. It is always advisable to connect a DMX terminal, (Resistance 120 Ohm 1/4 W) between PIN 2 (DMX-) and PIN 3 (DMX +) of the last fixture.

Figure 4

**5-Pin XLR DMX Connectors.** Some manufactures use 5-pin DMX-512 data cables for DATA transmission in place of 3-pin. 5-pin DMX fixtures may be implemented in a 3-pin DMX line. When inserting standard 5-pin data cables in to a 3-pin line a cable adaptor must be used, these adaptors are readily available at most electric stores. The chart below details a proper cable conversion.

3-Pin XLR to 5-Pin XLR Conversion		
Conductor	3-Pin XLR Female (Out)	5-Pin XLR Male (In)
Ground/Shield	Pin 1	Pin 1
Data Compliment (- signal)	Pin 2	Pin 2
Data True (+ signal)	Pin 3	Pin 3
Not Used		Do Not Use
Not Used		Do Not Use

All fixtures should be given a DMX starting address when using a DMX controller, so the correct fixture responds to the correct control signal. This digital starting address is the channel number from which the fixture starts to “listen” to the digital control signal sent out from the DMX controller. The assignment of this starting DMX address is achieved by setting the correct DMX address on the digital control display on the fixture.

You can set the same starting address for all fixtures or a group of fixtures, or set different addresses for each individual fixture. Setting all fixtures to the same DMX address will cause all fixtures to react in the same way, in other words, changing the settings of one channel will affect all the fixtures simultaneously.

If you set each fixture to a different DMX address, each unit will start to “listen” to the channel number you have set, based on the quantity of DMX channels of each fixture. That means changing the settings of one channel will only affect the selected fixture.

In the case of the Element QA, when in 4 channel mode you should set the starting DMX address of the first unit to 1, the second unit to 5 (4 + 1), the third unit to 9 (5 + 4), and so on. (See chart below for more details).

Channel Mode	Unit 1 Address	Unit 2 Address	Unit 3 Address	Unit 4 Address
4 Channels	1	5	9	13
5 Channels	1	6	11	16
6 Channels	1	7	13	19
9 Channels	1	10	19	28
10 Channels	1	11	21	31

**DMX Mode:**

Operating through a DMX controller gives the user the freedom to create their own programs tailored to their own individual needs. The Element QA has 5 DMX modes: 4 channel mode, 5 channel mode, 6 channel mode, 9 channel mode, and 10 channel mode. See pages 13-15 for each mode's DMX traits.

1. This function will allow you to control each individual fixtures traits with a standard DMX 512 controller.
2. To run your fixture in DMX mode press the MODE button until “**d.XXX**” is displayed. “**XXX**” represents the current displayed DMX address. Use the UP or DOWN buttons to select your desired DMX address, then press the SETUP button to select your DMX Channel mode.
3. Use the UP or DOWN buttons to scroll through the DMX Channel modes. The Channel modes are listed below:
  - To run the 4 Channel Mode, press the MODE button until “**Ch04**” is displayed.
  - To run the 5 Channel Mode, press the MODE button until “**Ch05**” is displayed.
  - To run the 6 Channel Mode, press the MODE button until “**Ch06**” is displayed.
  - To run the 9 Channel Mode, press the MODE button until “**Ch09**” is displayed.
  - To run the 10 Channel Mode, press the MODE button until “**Ch10**” is displayed.
4. Please see pages 13-15 for DMX values and traits.
5. After you have chosen your desired DMX address and channel mode plug in the fixture via the XLR connections to any standard DMX controller.

4 CH	5 CH	6 CH	9 CH	10 CH	VALUES	FUNCTIONS
1	1	1	1	1	000-255	<b>RED</b> 0~100%
2	2	2	2	2	000-255	<b>GREEN</b> 0~100%
3	3	3	3	3	000-255	<b>BLUE</b> 0~100%
4	4	4	4	4	000-255	<b>AMBER</b> 0~100%
	5	5	5	5	000-255	<b>MASTER DIMMER</b> 0~100%
		6	6	6	000-031 032-063 064-095 096-127 128-159 160-191 192-223 224-255	<b>STROBING/SHUTTER</b> LED OFF LED ON STROBING SLOW-FAST LED ON PULSE STROBING SLOW-FAST LED ON RANDOM STROBING SLOW-FAST LED ON
			7	7	000-051 052-102 103-153 154-204 205-255	<b>PROGRAM SELECTION MODE</b> RGBA DIMMING MODE COLOR MACRO MODE COLOR CHANGE MODE COLOR FADE MODE SOUND ACTIVE MODE

**NOTE: 9 CHANNEL DMX MODE & 10 CHANNEL DMX MODE:**

When Channel 7 is between the values of 0-51, Channels 1-4 are used, and Channel 5 will control strobing.

When Channel 7 is between the values of 52-102, Channel 8 is in Color Macros Mode, and Channel 5 will control strobing.

When Channel 7 is between the values of 103-153, Channel 8 is in Color Change Mode, and Channel 9 will control the color change speed.

When Channel 7 is between the values of 154-204, Channel 8 is in Color Fade Mode, and Channel 9 will control the color fade speed.

When Channel 7 is between the values of 205-255, Channel 8 is in Sound Active Mode, and Channel 9 will control the sound sensitivity.

4 CH	5 CH	6 CH	9 CH	10 CH	VALUES	FUNCTIONS
						<b>PROGRAMS</b>
					000-255	<b>COLOR MACRO MODE</b> SEE COLOR MACRO CHART ON PAGES 16-17
						<b>COLOR CHANGE MODE</b>
					000-015	COLOR CHANGE 1
					016-031	COLOR CHANGE 2
					032-047	COLOR CHANGE 3
					048-063	COLOR CHANGE 4
					064-079	COLOR CHANGE 5
					080-095	COLOR CHANGE 6
					096-111	COLOR CHANGE 7
					112-127	COLOR CHANGE 8
					128-143	COLOR CHANGE 9
					144-159	COLOR CHANGE 10
					160-175	COLOR CHANGE 11
					176-191	COLOR CHANGE 12
					192-207	COLOR CHANGE 13
					208-223	COLOR CHANGE 14
					224-239	COLOR CHANGE 15
					240-255	COLOR CHANGE 16
						<b>COLOR FADE MODE</b>
					000-015	COLOR FADE 1
					016-031	COLOR FADE 2
					032-047	COLOR FADE 3
			8	8	048-063	COLOR FADE 4
					064-079	COLOR FADE 5
					080-095	COLOR FADE 6
					096-111	COLOR FADE 7
					112-127	COLOR FADE 8
					128-143	COLOR FADE 9
					144-159	COLOR FADE 10
					160-175	COLOR FADE 11
					176-191	COLOR FADE 12
					192-207	COLOR FADE 13
					208-223	COLOR FADE 14
					224-239	COLOR FADE 15
					240-255	COLOR FADE 16
						<b>SOUND ACTIVE MODE</b>
					000-015	SOUND ACTIVE MODE 1
					016-031	SOUND ACTIVE MODE 2
					032-047	SOUND ACTIVE MODE 3
					048-063	SOUND ACTIVE MODE 4
					064-079	SOUND ACTIVE MODE 5
					080-095	SOUND ACTIVE MODE 6
					096-111	SOUND ACTIVE MODE 7
					112-127	SOUND ACTIVE MODE 8
					128-143	SOUND ACTIVE MODE 9
					144-159	SOUND ACTIVE MODE 10
					160-175	SOUND ACTIVE MODE 11
					176-191	SOUND ACTIVE MODE 12
					192-207	SOUND ACTIVE MODE 13
					208-223	SOUND ACTIVE MODE 14
					224-239	SOUND ACTIVE MODE 15
					240-255	SOUND ACTIVE MODE 16



4 CH	5 CH	6 CH	9 CH	10 CH	VALUES	FUNCTIONS
			9	9	000-255 000-255	<b>PROGRAM SPEED/SOUND SENSITIVITY</b> PROGRAM SPEED SLOW-FAST LEAST SENSITIVE-MOST SENSITIVE
				10	000-020 021-040 041-060 061-080 081-100 101-255	<b>DIMMER CURVES</b> STANDARD STAGE TV ARCHITECTURAL THEATRE DEFAULT TO UNIT SETTING

Color No.	DMX VAULE	RGBA COLOR INTENSITY			
		RED	GREEN	BLUE	AMBER
OFF	0	0	0	0	0
Color1	1-4	80	255	234	80
Color2	5-8	80	255	164	80
Color3	9-12	77	255	112	77
Color4	13-16	117	255	83	83
Color5	17-20	160	255	77	77
Color6	21-24	223	255	83	83
Color7	25-28	255	243	77	77
Color8	29-32	255	200	74	74
Color9	33-36	255	166	77	77
Color10	37-40	255	125	74	74
Color11	41-44	255	97	77	74
Color12	45-48	255	71	77	71
Color13	49-52	255	83	134	83
Color14	53-56	255	93	182	93
Color15	57-60	255	96	236	96
Color16	61-64	238	93	255	93
Color17	65-68	196	87	255	87
Color18	69-72	150	90	255	90
Color19	73-76	100	77	255	77
Color20	77-80	77	100	255	77
Color21	81-84	67	148	255	67
Color22	85-88	77	195	255	77
Color23	89-92	77	234	255	77
Color24	93-96	158	255	144	144
Color25	97-100	255	251	153	153
Color26	101-104	255	175	147	147
Color27	105-108	255	138	186	138
Color28	109-112	255	147	251	147
Color29	113-116	151	138	255	138
Color30	117-120	99	0	255	100
Color31	121-124	138	169	255	138
Color32	125-128	255	255	255	255

Color No.	DMX VAULE	RGBA COLOR INTENSITY			
		RED	GREEN	BLUE	AMBER
Color33	129-132	255	206	143	0
Color34	133-136	254	177	153	0
Color35	137-140	254	192	138	0
Color36	141-144	254	165	98	0
Color37	145-148	254	121	0	0
Color38	149-152	176	17	0	0
Color39	153-156	96	0	11	0
Color40	157-160	234	139	171	0
Color41	161-164	224	5	97	0
Color42	165-168	175	77	173	0
Color43	169-172	119	130	199	0
Color44	173-176	147	164	212	0
Color45	177-180	88	2	163	0
Color46	181-184	0	38	86	0
Color47	185-188	0	142	208	0
Color48	189-192	52	148	209	0
Color49	193-196	1	134	201	0
Color50	197-200	0	145	212	0
Color51	201-204	0	121	192	0
Color52	205-208	0	129	184	0
Color53	209-212	0	83	115	0
Color54	213-216	0	97	166	0
Color55	217-220	1	100	167	0
Color56	221-224	0	40	86	0
Color57	225-228	209	219	182	0
Color58	229-232	42	165	85	0
Color59	233-236	0	46	35	0
Color60	237-240	8	107	222	0
Color61	241-244	255	0	0	0
Color62	245-248	0	255	0	0
Color63	249-252	0	0	255	0
Color64	253-255	0	0	0	255

MENU	SUBMENU	OPTIONS	FUNCTIONS
DMX MODE	Address	d001~d512	DMX Address Setting
	Channels	Ch04	4 DMX Channel Mode
		Ch05	5 DMX Channel Mode
		Ch06	6 DMX Channel Mode
		Ch09	9 DMX Channel Mode
		Ch10	10 DMX Channel Mode
	No DMX mode	Black	When the DMX signal is lost or interrupted, the unit will go into BLACKOUT mode.
LAST		When the DMX signal is lost or interrupted, the unit will hold at the LAST DMX setting.	
Prog		When the DMX signal is lost or interrupted, the unit will run an auto program.	
Delay mode	dr-0~dr-4	Select the unit delay mode	
SECONDARY	Secondary Setting	SEcd	Designate the unit as a Secondary unit in a primary-secondary set up.
DIMMER MODE	Red Dimmer	r.000~r.255	Adjust the intensity of the red color.
	Green Dimmer	g.000~g.255	Adjust the intensity of the green color.
	Blue Dimmer	b.000~b.255	Adjust the intensity of the blue color.
	White Dimmer	A.000~A.255	Adjust the intensity of the amber color.
	Flash Adjustment	F500~F5.15	Adjust the flash speed. "00" is Off, "01" is the slowest speed, and "15" is the fastest.
SOUND MODE	Sound Active	S001~S016	Select 1 of 16 sound active programs.
	Sensitivity Adjust	SJ-0~SJ-8	Adjust the sound sensitivity. "0" is the lowest level, and "8" is the highest level.
AUTO RUN MODE	Color Fade Mode	RF01~RF16	Select 1 of 16 color fade modes.
	Color Change Mode	RJ01~RJ16	Select 1 of 16 color change modes.
	Color Change & Color Fade Mode	R-JF	This mode will run both color change and color fade continuously.
	Speed Adjustment	SP01~SP16	Adjust the running speed of the current mode.
STATIC COLOR MODE	Color Select	CL00~CL64	Select 1 of 64 static colors.
	Flash Adjustment	F500~F5.15	Adjust the flash speed. "00" is Off, "01" is the slowest speed, and "15" is the fastest.
BATTERY LIFE ENERGY SAVE LOADING SET UP	Battery Life Display	b---	Displays the current battery life.
		b000~b100	"b--" means that the battery is not being used. "bXXX" means that the battery is in use. "XXX" represents the battery charge percentage. "b000" means that the battery has no charge. "b100" means that the battery is at full charge.
	Energy Saving Mode	b5on	Activates energy saving mode.
		b5oF	Deactivates energy saving mode.
Load On/Off Select	Loon	Activates battery power.	
	LooF	Deactivates battery power.	
OTHER	Display	don	LED display is always on.
		doFF	LED display turns off after 30 seconds.
	IR Remote On/Off	Iron	IR remote function is activated.
		IrOF	IR remote function is deactivated.
	Display Normal/Inverted	Stnd	LED digital display is normal.
		Inv	LED digital display is inverted.
	Menu Lock	LoC1	Deactivate display lock. (Display lock is not active)
		LoC2	Activate display lock. (Press the MODE button for 3 seconds to unlock the display)
LoC3		Activate display lock two. (Press UP-DOWN-UP-DOWN to unlock the display)	
Initialization Mode	deFA	Default to factory settings.	
WIFLY SET UP	WiFly Address	rC00~rC14	Set the WiFly address.
	WiFly Function On/Off	rCon	WiFly function is active.
		rCoF	WiFly function is deactive.

**Operating Power:**

There are two ways to supply power to this unit; battery power or AC power. **Note: You need to activate the LOAD function regardless of how you supply power.**

- **AC Power** - To run the unit using AC power, plug the unit into a power source, and activate the Load setting. When using AC power make sure the Battery Switch is in the OFF position.
- **Battery Power** - To run the unit using Battery power, switch the battery switch located on the bottom of the fixture into the “On” position, and activate the Load setting.

**Load Setting**

**This function needs to be activated regardless of using Battery power or AC power. This switch will activate LED PCB output.**

1. To activate Load, press the MODE button until either “bXXX”, “bsXX”, or “LoXX” is displayed. “XX” represents the current setting of those menus.
2. Press the SET UP button so that “LoXX” is displayed. “XX” represents either “on” or “oF” (Off).
3. Press the UP or DOWN buttons so that “on” is displayed.

**Energy Saving Mode**

This will decrease the LED’s brightness gradually when the battery life is less than 80%, this will extend the battery life.

1. To activate energy saving mode, press the MODE button until either “bXXX”, “bsXX”, or “LoXX” is displayed. “XX” represents the current setting of the displayed menu.
2. Press the SET UP button so that “bS:XX” is displayed. “XX” represents either “on” or “oF” (Off).
3. Press the UP or DOWN button so that “on” is displayed. If “on” is displayed then the fixture is already in energy saving mode.

**Display Lock:**

1. Plug the fixture in and press the MODE button until “dXX” is displayed. “XX” represents either “on” or “off”.
2. Plug the fixture in and press the SET UP button until “LoCX” is displayed. “X” represents a number between 1-3.
3. Press the UP or DOWN buttons to find your desired setting.
  - “LoC1” - The keypad will remain unlocked at all times.
  - “LoC2” - The keypad will lock after 10 seconds, press the MODE button for 3 seconds to unlock the keypad.
  - “LoC3” - This lock setting is used to prevent the accidental unlocking of the keypad. To unlock the keypad press UP, DOWN, UP, DOWN, in that order.

**LED Display On/Off:**

To set the LED display light to turn off after 20 seconds, press the MODE button until “dXX” is displayed. “XX” represents either “on” or “oFF”. Press the UP or DOWN buttons so that OFF is displayed. Now the display light will turn off after 30s. Press any button to turn the display on again.

**Operating Modes:**

The Element QA has five operating modes:

- **RGBA Dimmer Mode** - Choose one of the four colors to remain static or adjust the intensity of each color to make your desired color.
- **Sound Active mode** - The unit will react to sound, chasing through the built in programs. There are 16 sound active modes.
- **Auto Run Mode** - In Auto Run mode, you can choose 1 of 16 color change modes, 1 of 16 color fade modes, or a combination color change & color fade mode.
- **Static Color Mode** - There are 64 color macros to choose from.
- **DMX control mode** - This function will allow you to control each individual fixture traits with a standard DMX 512 controller.

**RGBA Dimmer Mode:**

1. Plug the fixture in and press the MODE button “**r: XXX**” is displayed. You now are in Red dimming mode. Press the UP and DOWN buttons to adjust intensity. After you have finished adjusting the intensity, or if you would like to skip to the next color, press the SET UP button.
2. When “**G: XXX**” is displayed you are in Green dimming mode. Press the UP and DOWN buttons to adjust intensity.
3. When “**b: XXX**” is displayed you are in Blue dimming mode. Press the UP and DOWN buttons to adjust intensity.
4. When “**A: XXX**” is displayed you are in Amber dimming mode. Press the UP and DOWN buttons to adjust intensity.
5. After you have adjusted the colors to make your desired color you can then activate strobing by pressing the SET UP button to enter the strobe mode.
6. “**FS: XX**” will be displayed, this is strobe mode. The strobe can be adjusted between “**00**” (flash off) to “**15**” (fastest flash).

**Sound Active Mode:**

1. Plug the fixture in and press the MODE button until “**SoXX**” is displayed. “XX” represents the current sound active mode (1-16).
2. Use the UP or DOWN buttons to find your desired sound active mode.
3. Press the SET UP button to enter sound sensitivity adjustment. “**SJ-X**” will be displayed. Use the UP or DOWN buttons to adjust the sensitivity. “**SJ-1**” is the lowest sensitivity, “**SJ-8**” is the highest. “**SJ-0**” turns the sound sensitivity off.

**Static Color Mode (Color Macros):**

1. Plug the fixture in and press the MODE button until “**CLXX**” is displayed.
2. There are 64 colors to choose from. Select your desired color by pressing the UP and DOWN buttons. After you have selected your desired color you can activate strobing by pressing the SET UP button to enter the Flash (strobe) mode.
3. “**FS.XX**” will be displayed, this is Flash mode. The Flash can be adjusted between “**FS.00**” (flash off) to “**FS.15**” (fastest flash).

**Auto Run Mode:**

There are 3 types of Auto Run Modes to choose from; Color Fade, Color Change, and both color change and color fade modes running together. The running speed is adjustable in all 3 modes.

1. Plug the fixture in and press the MODE button until either “**AFX**”, “**AJX**”, or “**A-JF**” is displayed.
  - **AFX** - Color Fade mode, there are 16 Color Fade modes to choose from. Use the UP or DOWN buttons to scroll through the different Auto Fade modes.
  - **AJX** - Color Change mode, there are 16 Color Change modes to choose from. Use the UP or DOWN buttons to scroll through the different Auto Change modes.
  - **A-JF** - Both Color Fade and Color Change modes running.
2. After you have chosen your desired running mode press the SET UP button until “**SP.XX**” is displayed. When this is displayed you can adjust the running speed of your desired program. Use the UP or DOWN button to adjust the speed between “**SP.01**” (slowest) and “**SP.16**” (fastest). Once you have set your desired running speed, press the SET UP button to return to your selected Auto Run mode.

**DMX Mode:**

Operating through a DMX controller gives the user the freedom to create their own programs tailored to their own individual needs. The Element QA has 5 DMX modes: 4 channel mode, 5 channel mode, 6 channel mode, 9 channel mode, and 10 channel mode. See pages 14-15 for each mode’s DMX traits.

1. This function will allow you to control each individual fixtures traits with a standard DMX 512 controller.
2. To run your fixture in DMX mode press the MODE button until “**d.XXX**” is displayed. “**XXX**” represents the current displayed DMX address. Use the UP or DOWN buttons to select your desired DMX address, then press the SETUP button to select your DMX Channel mode.
3. Use the UP or DOWN buttons to scroll through the DMX Channel modes. The Channel modes are listed below:
  - To run the 4 Channel Mode, press the MODE button until “**Ch04**” is displayed.
  - To run the 5 Channel Mode, press the MODE button until “**Ch05**” is displayed.
  - To run the 6 Channel Mode, press the MODE button until “**Ch06**” is displayed.
  - To run the 9 Channel Mode, press the MODE button until “**Ch09**” is displayed.
  - To run the 10 Channel Mode, press the MODE button until “**Ch010**” is displayed.
4. After you have chosen your desired DMX Channel mode plug in the fixture via the XLR connections to any standard DMX controller.

**Dimmer Curve:**

This is used to set the dimmer curve used with DMX mode. See page 25 for the dimmer curve chart.

1. Plug the fixture in and press the MODE button until “**d.XXX**” is displayed. “**XXX**” represents the current displayed DMX address.
2. Press the SET UP button until “**dr-X**” is displayed. “**X**” represents the current displayed dimmer curve setting (0-4).
  - **0 - Standard**
  - **1 - Stage**
  - **2 - TV**
  - **3 - Architectural**
  - **4 - Theatre**
3. Press the UP or DOWN buttons to scroll through and select your desired dimming curve.



**DMX State:**

This mode can be used as a precaution mode, that in case the DMX signal is lost, the operating mode chosen in the setup is the running mode the fixture will go into when the DMX signal is lost. You can also set this as the operating mode you would like the unit to return to when power is applied.

1. Plug the fixture in and press the MODE button until “**d.XXX**” is displayed. “**XXX**” represents the current displayed DMX address.
2. Press the SET UP button so that “**nodn**” is displayed. Use the UP and DOWN buttons to scroll through the DMX states.
  - “**bLAC**” (**Blackout**) - If the DMX signal is lost or interrupted, the unit will automatically go into stand by mode.
  - “**LASt**” (**Last State**) - If the DMX signal is lost or interrupted, the fixture will stay in the last DMX set up. If power is applied and this mode is set, the unit will automatically go into the last DMX set up.
  - “**ProG**” (**Auto Run**) - If the DMX signal is lost or interrupted, the unit will automatically go into Auto Run mode.
3. After you have found your desired setting, press SET UP to exit.

**WiFly On/Off and Wireless Addressing:**

This function is used to activate the WiFly control and set the WiFly address.

**NOTE: The address must match the address that is set to WiFly Transceiver or WiFly controller.**

1. Plug the fixture in and press the MODE button until “**rCXX**” is displayed. This is the wireless set up mode.
2. Press the UP or DOWN buttons the UP or DOWN buttons to turn the Wireless “**On**” or “**Of**”(Off).
3. Press the SET UP button to enter the Wireless address menu. Use the UP or DOWN buttons to select your desired Wireless address.

**Activate IR Sensor:**

This function is used to activate and deactivate the IR sensor. When this function is activated you can control the fixture using the UC IR remote or Airstream IR App. Please see page 24 for controls and functions.

1. Plug the fixture in and press the MODE button until “**dXX**” is displayed. “**XX**” represents either “**on**” or “**oF**” (Off).
2. Press the SET UP button until “**IrXX**” is displayed. “**XX**” represents either “**on**” or “**oF**” (Off).
3. Press the UP or DOWN buttons to either activate the remote function (On) or deactivate it (Off).

**Secondary Setting:**

This function is used to designate the unit as a “**Secondary**” unit in a Primary-Secondary set up.

1. Plug the fixture in and press the MODE button until “**SEcd**” is displayed. The unit is now designated as a “Secondary” unit in a Primary-Secondary set up.

**Default Running Mode:**

This is a default running mode. When this mode is activated all modes will return to their default settings.

1. Plug the fixture in and press the MODE button until “**dXX**” is displayed. “**XX**” represents either “**on**” or “**oF**”.
2. Press the SET UP button until “**dEFA**” is displayed.
3. Press the UP and DOWN buttons simultaneously. Press the MODE button to exit.

**Primary-Secondary Set Up:**

This function will allow you to link units together to run in a Primary set-up. In a Primary-Secondary set up one unit will act as the controlling unit and the others will react to the controlling units built-in programs. Any unit can act as a Primary or as a Secondary however, only one unit can be programmed to act as the "Primary".

**Primary-Secondary Connections and Settings:**

1. Daisy chain your units via the XLR connector on the rear of the unit. Use standard XLR data cables to link your units together. Remember that the Male XLR connector is the input and the Female XLR connector is the output. The first unit in the chain (primary) will use the female XLR connector only. The last unit in the chain will use the male XLR connector only.
2. Connect the first "Secondary" unit to the "Primary."
3. Set the "Primary" unit to your desired mode of operation. On the "Secondary" unit(s) press the MODE button until "**Secd**" is displayed. See page 22 "**Secondary Setting**".

This unit can only be controlled using WiFly. Your DMX controller must be connected to a ADJ WiFly Transceiver to use this function. You are able to communicate up to 2500 feet/760 meters (open line of sight).

1. Follow the instructions on page 22 to set the WiFly address and to activate WiFly. The address must match the address set on the WiFly WiFly Transceiver.
2. After you have set the WiFly address, follow the DMX instructions on page 21 to select your desired DMX Channel mode and set your DMX address.
3. Apply power to the ADJ WiFly Transceiver. The fixture must be set up first before you apply power to WiFly Transceiver.
4. If everything is set up properly and the fixture is receiving a Wireless signal, you should now be able to control it with a DMX controller.

**WiFly Primary-Secondary Set Up:**

This function will allow you to link units together via WiFly to run in a Primary-Secondary setup.

1. Follow the instructions on page 22 to set the WiFly address and to activate WiFly. The addresses on each fixture must be the same.
2. After you have set the WiFly address, select your "Primary" unit and set your desired operating mode.
3. Set the "Primary" unit to your desired mode of operation. On the "Secondary" unit(s) press the MODE button until "**SEcd**" is displayed. See page 22 "**Secondary Setting**".
4. If everything is set up correctly, the "Secondary" units will start following the "Primary" unit.

The **UC IR (sold separately)** infrared remote gives you control of various functions (See below). To control the fixture you must aim the remote at the front of the fixture and be no more than 30 feet away. To use the ADJ UC IR you must first activate the fixtures infrared sensor, to activate the sensor please see the instructions on page 22.

The **Airstream IR (sold separately)** remote transmitter plugs into the headphone jack of your iOS phone or tablet. To control your IR fixture you must raise the volume to the maximum on your iOS phone or tablet and aim the transmitter at the fixture sensor and be no more than 15 feet away. After you have purchased the Airstream IR transmitters, the app is a free download from the app store for your iOS phone or tablet. The app comes with 3 pages of control depending on the fixture you are using. Please see below for the IR functions including the corresponding app page.

		Stand by
Full ON	Fade/Gobo	
Strobe	Color	
1	2	3
4	5	6
7	8	9
SoundOn	Show 0	SoundOff

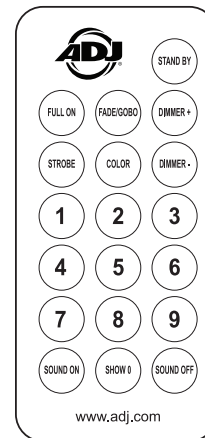

**Works with App page 1.**

**STAND BY** - Pressing this button will blackout the fixture. Press the button again to return to the initial state.

**FULL ON** - Press this button to fully light up the unit.

**FADE/GOBO** - This button can activate color change mode, color fade mode, or combination color change and fade mode. Each press of the button will switch through the 3 different modes. Use the numeral buttons 1-9 to select the program number within your desired mode. Use the dimmer buttons to adjust the output intensity. **Note:** Running speed is not adjustable using the IR control functions.

**Example:** In color change mode (AJXX), press the numeral buttons “1+3” to run color change program “13”. In color fade mode (AFX), press the numeral button “7” to run color fade program “7”.

**Note:** Color change and fade combination mode has only one program.

**“DIMMER +” and “DIMMER -”** - Use these buttons to adjust the output intensity in operating mode.

**STROBE** - Press this button to activate strobing. Use buttons 1-4 to adjust the strobe speed. “1” being the slowest, “4” being the fastest.

**COLOR** - Press this button to activate color macro mode. Use the numeral buttons 1-9 to select your desired color. Use the dimmer buttons to adjust the output intensity.

**Numeral Buttons 1-9** - Use buttons 1-9 to select your desired color in static color mode, or your desired program in color fade mode and color change mode. In static color mode, color fade mode, or color change mode, press the corresponding numeral buttons to select your desired color or program.

**SOUND ON & OFF** - Use the buttons to activate and deactivate sound active mode.

**SHOW 0** - Press this button along with any single numeral button to access a static color, or program within color change mode and color fade mode.

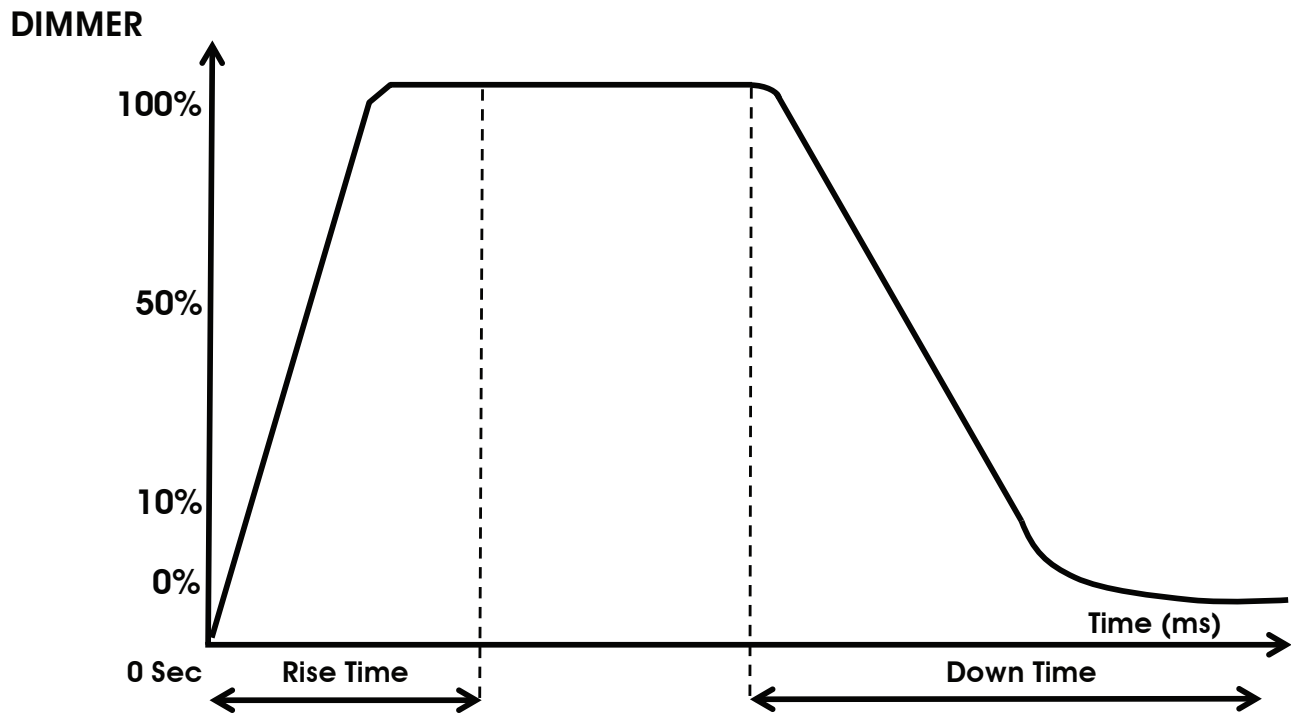

Dimming Curve Ramp Effect	0 sec Fade Time		1 sec Fade Time	
	Rise Time (ms)	Down Time (ms)	Rise Time (ms)	Down Time (ms)
Standard (default)	0	0	0	0
Stage	780	1100	1540	1660
TV	1180	1520	1860	1940
Architectural	1380	1730	2040	2120
Theatre	1580	1940	2230	2280

**Element QA**

**Dimensional Drawing**

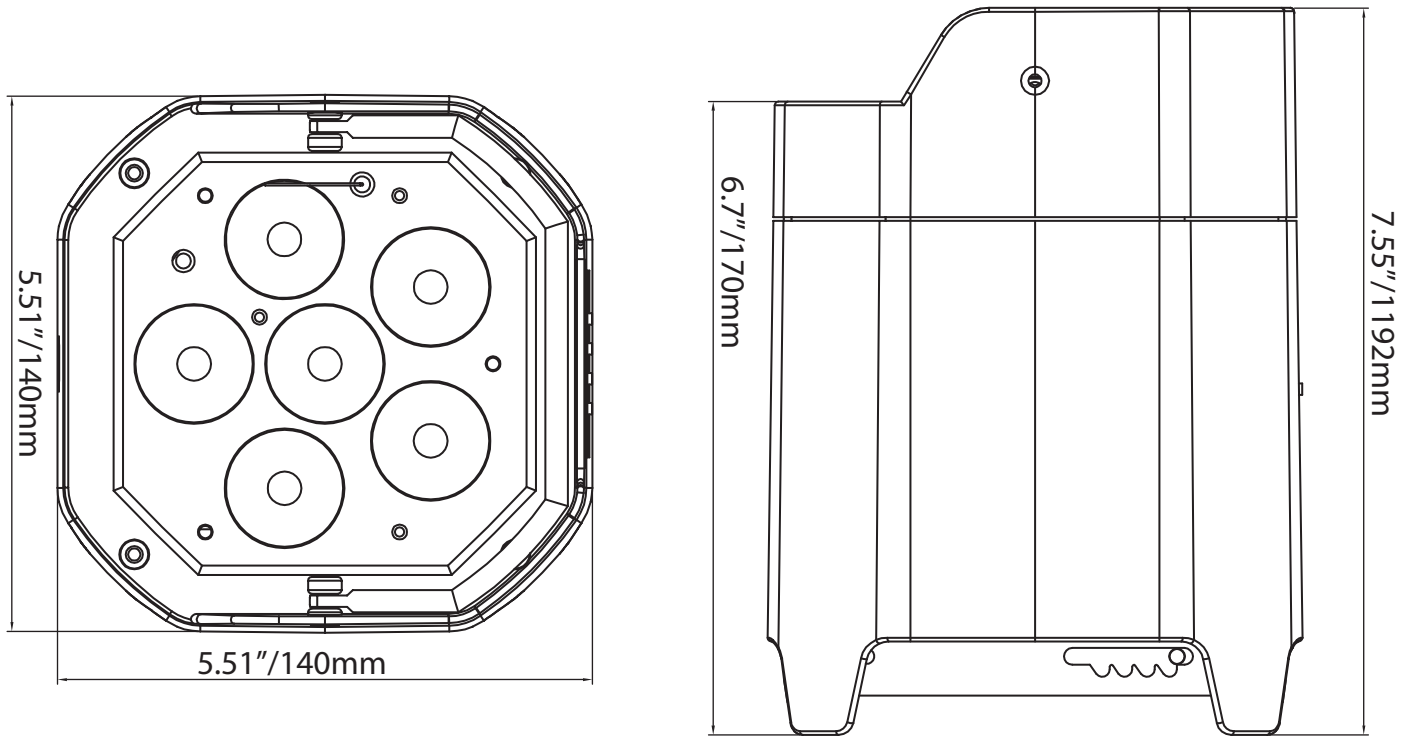

**Element QA**

**Kickstand Angles**

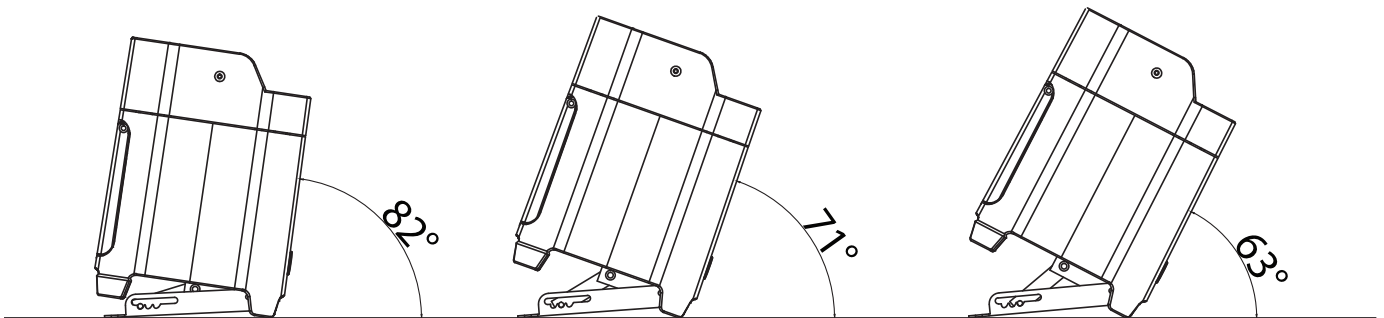

## Element QA

## Multiple Unit Power Linking

With this feature you can connect the fixtures to one another using the power cable input and output sockets.

**NOTE: USE CAUTION WHEN POWER LINKING OTHER FIXTURES AS THE POWER CONSUMPTION OF OTHER MODEL FIXTURES MAY EXCEED THE MAX POWER OUTPUT ON THIS FIXTURE! CHECK SILK SCREEN FOR MAX AMPS.**

## Element QA

## Fuse Replacement

Disconnect the unit from its power source. Remove the power cord from the unit. Once the cord has been removed, you will find that the fuse holder is located inside the power socket. Insert a flat-head screw driver into the power socket and gently pry out the fuse holder. Remove the bad fuse and replace with a new one. The fuse holder also has a holder for a spare fuse.

## Element QA

## Trouble Shooting

Listed below are a few common problems the user may encounter, with solutions.

### **Unit not responding to DMX:**

1. Check that the DMX cables are connected properly and are wired correctly (pin 3 is “hot”; on some other DMX devices pin 2 may be ‘hot’). Also, check that all cables are connected to the right connectors; it does matter which way the inputs and outputs are connected.

### **Unit does not respond to sound:**

1. Quiet or high pitched sounds will not activate the unit.
2. Make sure that Sound Active mode is activated.

## Element QA

## Cleaning

Due to fog residue, smoke, and dust cleaning the internal and external optical lenses must be carried out periodically to optimize light output.

1. Use normal glass cleaner and a soft cloth to wipe down the outside casing.
2. Clean the external optics with glass cleaner and a soft cloth every 20 days.
3. Always be sure to dry all parts completely before plugging the unit back in.

Cleaning frequency depends on the environment in which the fixture operates (i.e. smoke, fog residue, dust, dew).

## Element QA

## Optional Accessories

ORDER CODE	ITEM
EPC600	6-PACK SKB CASE
EFC800	8-PACK CHARGING CASE

**MANUFACTURER'S LIMITED WARRANTY**

- A. ADJ Products, LLC hereby warrants, to the original purchaser, ADJ Products, LLC products to be free of manufacturing defects in material and workmanship for a prescribed period from the date of purchase (see specific warranty period on reverse). This warranty shall be valid only if the product is purchased within the United States of America, including possessions and territories. It is the owner's responsibility to establish the date and place of purchase by acceptable evidence, at the time service is sought.
- B. For warranty service you must obtain a Return Authorization number (RA#) before sending back the product—please contact ADJ Products, LLC Service Department at 800-322-6337. Send the product only to the ADJ Products, LLC factory. All shipping charges must be pre-paid. If the requested repairs or service (including parts replacement) are within the terms of this warranty, ADJ Products, LLC will pay return shipping charges only to a designated point within the United States. If the entire instrument is sent, it must be shipped in its original package. No accessories should be shipped with the product. If any accessories are shipped with the product, ADJ Products, LLC shall have no liability whatsoever for loss of or damage to any such accessories, nor for the safe return thereof.
- C. This warranty is void if the serial number has been altered or removed; if the product is modified in any manner which ADJ Products, LLC concludes, after inspection, affects the reliability of the product; if the product has been repaired or serviced by anyone other than the ADJ Products, LLC factory unless prior written authorization was issued to purchaser by ADJ Products, LLC; if the product is damaged because not properly maintained as set forth in the instruction manual.
- D. This is not a service contract, and this warranty does not include maintenance, cleaning or periodic check up. During the period specified above, ADJ Products, LLC will replace defective parts at its expense with new or refurbished parts, and will absorb all expenses for warranty service and repair labor by reason of defects in material or workmanship. The sole responsibility of ADJ Products, LLC under this warranty shall be limited to the repair of the product, or replacement thereof, including parts, at the sole discretion of ADJ Products, LLC. All products covered by this warranty were manufactured after August 15, 2012, and bear identifying marks to that effect.
- E. ADJ Products, LLC reserves the right to make changes in design and/or improvements upon its products without any obligation to include these changes in any products theretofore manufactured.

No warranty, whether expressed or implied, is given or made with respect to any accessory supplied with products described above. Except to the extent prohibited by applicable law, all implied warranties made by ADJ Products, LLC in connection with this product, including warranties of merchantability or fitness, are limited in duration to the warranty period set forth above. And no warranties, whether expressed or implied, including warranties of merchantability or fitness, shall apply to this product after said period has expired. The consumer's and/or Dealer's sole remedy shall be such repair or replacement as is expressly provided above; and under no circumstances shall ADJ Products, LLC be liable for any loss or damage, direct or consequential, arising out of the use of, or inability to use, this product.

This warranty is the only written warranty applicable to ADJ Products, LLC Products and supersedes all prior warranties and written descriptions of warranty terms and conditions heretofore published.

**MANUFACTURER'S LIMITED WARRANTY PERIODS:**

- **Non L.E.D. Lighting Products = 1-year (365 days) Limited Warranty** (Such as: Special Effect Lighting, Intelligent Lighting, UV lighting, Strobes, Fog Machines, Bubble Machines, Mirror Balls, Par Cans, Trussing, Lighting Stands etc. excluding LED and lamps)
- **Laser Products = 1 Year (365 Days) Limited Warranty** (excluding laser diodes which have a 6 month limited warranty)
- **L.E.D. Products = 2-year (730 days) Limited Warranty** (excluding batteries which have a 180 day limited warranty). **Note: 2 Year Warranty only applies to purchases within the United States.**
- **StarTec Series = 1 Year Limited Warranty** (excluding batteries which have a 180 day limited warranty).
- **ADJ DMX Controllers = 2 Year (730 Days) Limited Warranty**



**Model: Element QA**

Voltage:	100V ~ 240V/50~60Hz
LEDs:	6 x 5W RGBA (4-in-1) LEDs
Beam Angle:	20 Degrees
Working Position:	Any safe working position
Fuse:	250V, 2 Amp
Power Draw:	42W
Weight:	5lbs./ 2.26Kgs.
Dimensions:	5.51" (L) x 5.51" (W) x 7.55" (H) 140 x 140 x 192mm
Colors:	RGBA Mixing
DMX Channels:	5 DMX Modes: 4 Channel Mode, 5 Channel Mode, 6 Channel Mode, 9 Channel Mode, & 10 Channel Mode
Battery Charge Time:	4 Hours (With Load Switch OFF & Power Switch ON)
Battery Life:	<b>BATTERY SAVING MODE OFF</b> 7.5 Hours (Full Charge Single Color) 4 Hours (Full On) <b>BATTERY SAVING MODE ON</b> 21 Hours (Full Charge Single Color) 10 Hours (Full On)
Battery Lifetime*:	Average Lifetime is 500 Charges
Battery Type:	Fixed Lithium Battery
Battery Energy:	73.26WH (Watt Hours)
Battery Weight:	1lbs. / 0.42kg
Battery Voltage:	11.1V
Battery Capacity:	6.6AH
Total Lithium Ion Cells:	9pcs
Battery Wrap Material:	PVC Sleeving + Highland Barley Paper
Warranty:	2 Year (730 days)

\*This depends on charging frequency

\*\*See Warranty page for more details

**Please Note:** Specifications and improvements in the design of this unit and this manual are subject to change without any prior written notice.