

Tetrapad

Multi-Dimensional Performance Touch Controller

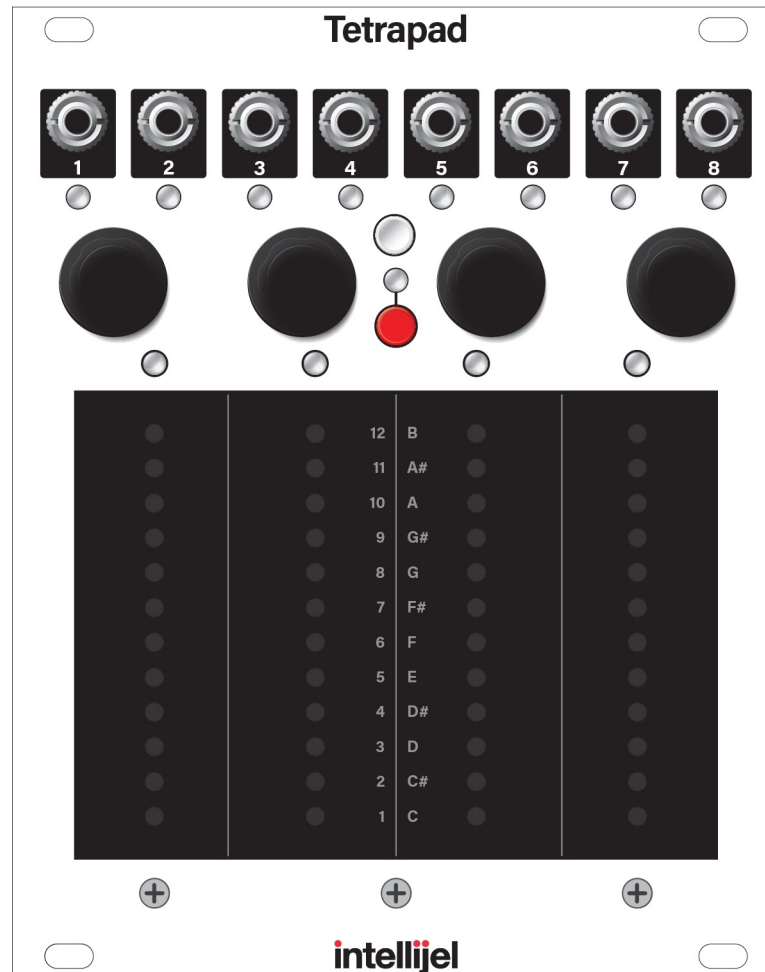

IMPORTANT!

This manual discusses Tetrapad when it's used as a standalone module, and not when it's used in conjunction with Tête.

If you're using Tetrapad with Tête, read and refer to the Tête + Tetrapad Manual instead.

Firmware Version: 3.0.0.3

Manual Revision: 2020.03.29

Table of Contents

Compliance	4
Installation	5
Installing Your Module	5
Overview	7
Panel Reference	8
Modes Overview	12
Combo Mode	13
Single Function Modes	14
Configuration Modes	15
Selecting Modes & Loading a Mode Preset	16
Saving Mode Presets	18
Auto-Saving	19
Mode Reset	19
Mode 1: Combo Mode	20
Combo Mode: Unipolar Fader	21
Assigning Unipolar Fader Functionality To A Pad	22
Using Unipolar Faders	22
Slew Between Fader Settings	23
Combo Mode: Bipolar Fader	24
Assigning Bipolar Fader Functionality To A Pad	25
Using Bipolar Faders	25
Slew Between Fader Settings	26
Combo Mode: Drum Pad	27
Assigning Drum Pad Functionality To A Pad	28
Using Drum Pads	28

Combo Mode: Switches	29
Assigning Switches Functionality To A Pad	30
Using Switches	30
Combo Mode: LFO	31
Assigning LFO Functionality To A Pad	32
Using an LFO (Overview)	32
Using LFO EDIT View	33
Using LFO PERFORMANCE Mode	34
Mode 2: Voltages Mode	35
Using Voltages Mode	36
Edit a Button's Stored Voltages	37
Randomize a Single Stored Voltage	37
Randomize all 8 Stored Voltages for a Button	38
Reset a Stored Voltage to 0V	38
Slew Between Stored Voltages	38
Mode 3: Keyboard Mode	39
Using Keyboard Mode	40
EDIT VIEW: Assigning Keys According to Scale	40
PERFORMANCE VIEW: Playing the Keyboard	42
Slew Between Notes	44
Tuning Mode	44
Mode 4: Custom Keyboard Mode	45
Using Custom Keyboard Mode	46
Manual Note Assignment	46
Slew Between Notes	48
Playing the Keyboard	48
Tuning Mode	48

Mode 5: Chord Mode	49
Using Chord Mode	50
Chord Selection	50
Slew Between Chords	52
Performing in Chord Mode	52
Tuning Mode	53
Mode 6: Custom Chord Mode	54
Using Custom Chord Mode	55
Chord Entry	55
Slew Between Chords	56
Performing in Custom Chord Mode	56
Tuning Mode	58
Mode 12: Global Configuration	59
Using Global Configuration Mode	60
Output Voltage Calibration	62
Firmware Version Display	65
Version 3 Firmware Display Method	65
Version 1 & 2 Firmware Display Method	66
Firmware Change Log	67
Technical Specifications	69

Compliance



This device complies with Part 15 of the FCC Rules. Operation is subject to the following two conditions: (1) this device may not cause harmful interference, and (2) this device must accept any interference received, including interference that may cause undesired operation.

Changes or modifications not expressly approved by Intellijel Designs, Inc. could void the user's authority to operate the equipment.

Any digital equipment has been tested and found to comply with the limits for a Class A digital device, pursuant to part 15 of the FCC Rules. These limits are designed to provide reasonable protection against harmful interference when the equipment is operated in a commercial environment. This equipment generates, uses, and can radiate radio frequency energy and, if not installed and used in accordance with the instruction manual, may cause harmful interference to radio communications.



This device meets the requirements of the following standards and directives:

EMC: 2014/30/EU

EN55032:2015 ; EN55103-2:2009 (EN55024) ; EN61000-3-2 ; EN61000-3-3

Low Voltage: 2014/35/EU

EN 60065:2002+A1:2006+A11:2008+A2:2010+A12:2011

RoHS2: 2011/65/EU

WEEE: 2012/19/EU

Installation

Intellijel Eurorack modules are designed to be used with a Eurorack-compatible case and power supply. We recommend you use Intellijel cases and power supplies.

Before installing a new module in your case, you must ensure your power supply has a free power header and sufficient available capacity to power the module:

- Sum up the specified +12V current draw for all modules, including the new one. Do the same for the -12 V and +5V current draw. The current draw will be specified in the manufacturer's technical specifications for each module.
- Compare each of the sums to specifications for your case's power supply.
- Only proceed with installation if none of the values exceeds the power supply's specifications. Otherwise you must remove modules to free up capacity or upgrade your power supply.

You will also need to ensure your case has enough free space (hp) to fit the new module. To prevent screws or other debris from falling into the case and shorting any electrical contacts, do not leave gaps between adjacent modules, and cover all unused areas with blank panels. Similarly, do not use open frames or any other enclosure that exposes the backside of any module or the power distribution board.

You can use a tool like [ModularGrid](#) to assist in your planning. Failure to adequately power your modules may result in damage to your modules or power supply. If you are unsure, please [contact us](#) before proceeding.

Installing Your Module

When installing or removing a module from your case always turn off the power to the case and disconnect the power cable. Failure to do so may result in serious injury or equipment damage.

Ensure the 10-pin connector on the power cable is connected correctly to the module before proceeding. The red stripe on the cable must line up with the -12V pins on the module's power connector. The pins are indicated with the label -12V, a white stripe next to the connector, the words "red stripe", or some combination of those indicators.

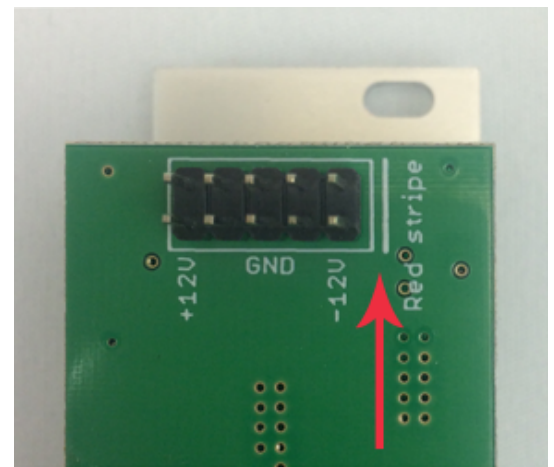

Most modules will come with the cable already connected but it is good to double check the orientation. Be aware that some modules may have headers that serve other purposes so ensure the cable is connected to the right one.

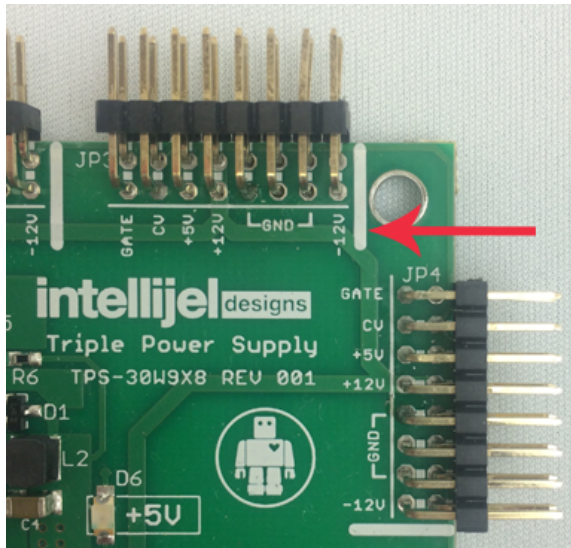

The other end of the cable, with a 16-pin connector, connects to the power bus board of your Eurorack case. Ensure the red stripe on the cable lines up with the -12V pins on the bus board. On Intellijel power supplies the pins are labelled with the label “-12V” and a thick white stripe:

If you are using another manufacturer’s power supply, check their documentation for instructions.

Once connected, the cabling between the module and power supply should resemble the picture below:

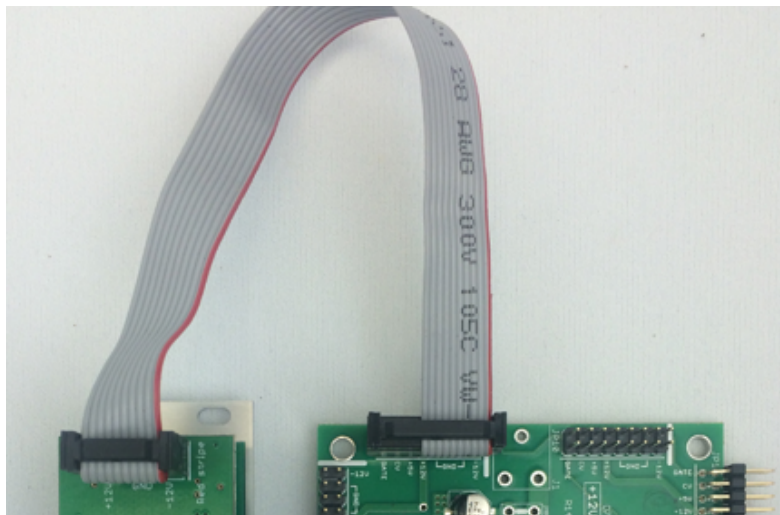

Before reconnecting power and turning on your modular system, double check that the ribbon cable is fully seated on both ends and that all the pins are correctly aligned. If the pins are misaligned in any direction or the ribbon is backwards you can cause damage to your module, power supply, or other modules.

After you have confirmed all the connections, you can reconnect the power cable and turn on your modular system. You should immediately check that all your modules have powered on and are functioning correctly. If you notice any anomalies, turn your system off right away and check your cabling again for mistakes.

Overview

Tetrapad is a versatile, multi-dimensional, touch-sensitive control surface for Eurorack. Each of its four pads use force sensing resistors to respond to both the vertical position of your finger and its pressure. Four push encoders and a shift function give you even more tactile control over your modular system.

Tetrapad operates in numerous modes — each of which configures the module to perform a specific control task. Through these modes, Tetrapad becomes an 8-key keyboard; a voltage storage device; or a 4-note chord generator. In its special Combo Mode, each pad can be assigned a function independent of the other three pads, such as: a fader; a bi-polar fader; an LFO; a dual switch; or a finger drumming pad. The chosen mode determines what type of signal (CV, note, trigger, gate, etc.) is sent from each of Tetrapad's eight independent outputs, while its multitude of multi-colored LEDs keep you informed of exactly what's happening within each mode.

Each mode contains 12 memory slots for that mode, allowing you to instantly recall one of 12 different custom keyboards; one of 12 different voltage maps; one of 12 fader/LFO/switch combinations; etc.

Tetrapad automatically remembers how you've configured each of its modes, and retains these settings when powered off. By default, Tetrapad automatically saves these settings every minute, or whenever you change modes. This makes Tetrapad ideal for live performance, since you know it will always power up with your configurations intact.

Panel Reference

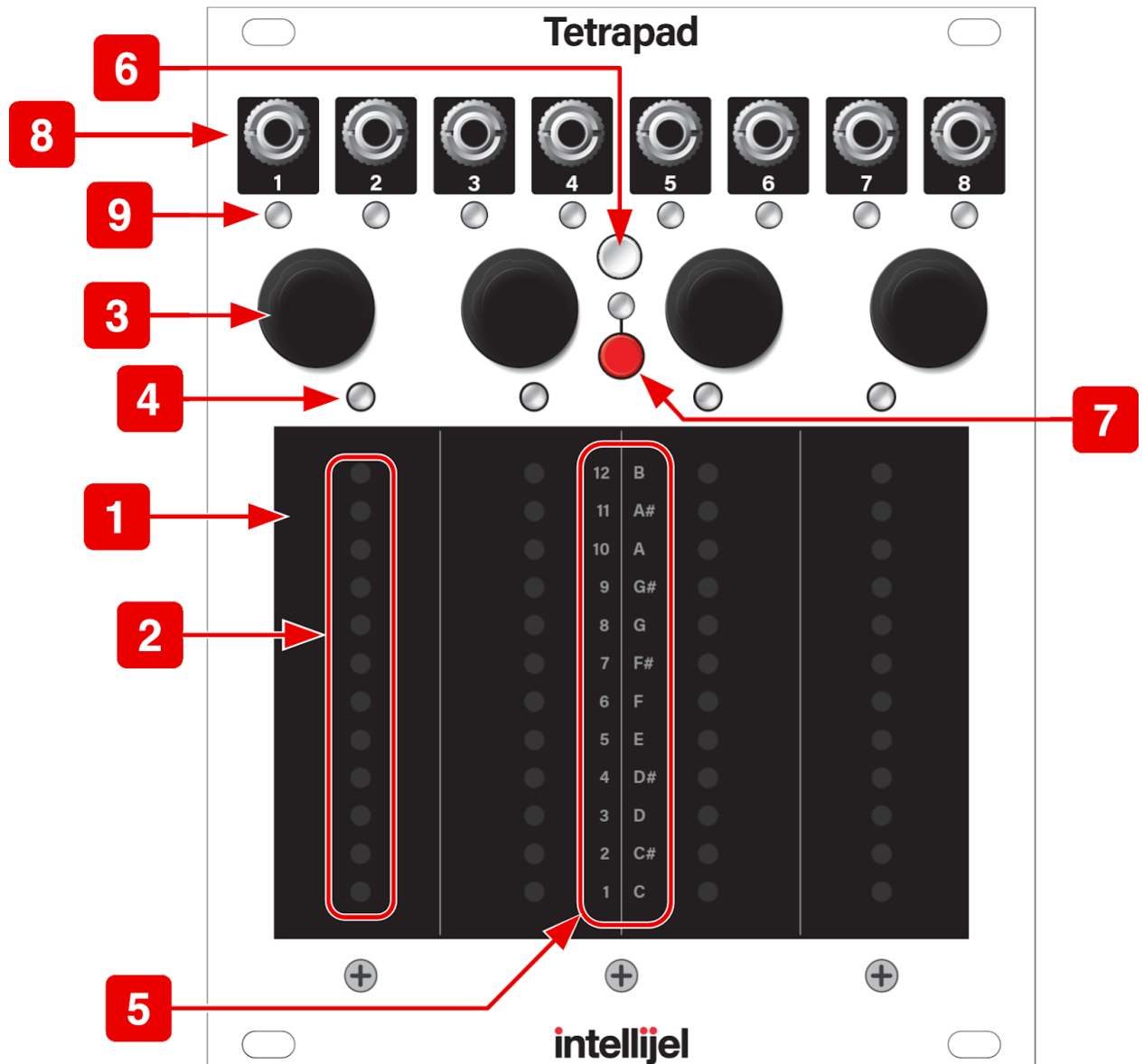

1. Pads 1-4

Four identical touch strips, each of which is sensitive to both vertical position and finger pressure. Depending on Tetrapad's current mode, these pads can transmit trigger signals, gate signals, quantized note values or real-time control voltages.

2. Level LEDs

Embedded beneath the surface of each pad is a 12 LED ladder. This ladder displays different parameter values in different modes. When operating as a basic fader, the LEDs represent the fader's level; when operating as note triggers, they represent the note assignment; when selecting modes, they display identifying mode numbers, presets numbers, or Combo Mode animations.

3. Push Encoders 1-4

Each of the four pads has its own associated push encoder, which functions differently depending on Tetrapad's current mode. For example, in Custom Keyboard Mode, the encoders assign note values for each output. In Voltages Mode, the encoders assign voltage values to an output. Similarly, pressing the encoder has different functions depending on the mode. For example, if you've assigned a fader to a pad in Combo Mode, pressing an encoder latches that fader's value. Not every function uses the encoders, so please read each specific mode discussion to learn more.

4. Pad Status LEDs 1-4

Some modes use these LEDs to indicate a pad's status. For example, they may indicate whether or not a pad's fader level is latched; or to which octave a note belongs.

5. Level Labels

This vertical column of text provides meaningful labels to each of the 12 vertically stacked Level LEDs. On the right are note names, which indicate pitch when appropriate to the selected mode. On the left are numbers 1-12 for indicating numerical values.

6. EDIT Button

This button has two distinct operations: one (a long-press) enables selecting the main Mode under which Tetrapad operates; the other (a short-press) enables selecting individual Pad assignments in Combo Mode. Specifically:

- **Selecting Modes:** Long-hold (>1 sec) this button to enable Mode selection (See [Modes Overview](#) for more information).

When Mode Select is enabled, the eight Output Status LEDs light up, and a Level LED on the left-of-center pad also lights to indicate which mode number is currently selected. To select different modes, rotate either of the two left encoders — a bright mode indicator Level LED moves up/down to indicate the mode number.

Once you select the desired mode, use either of the two right encoders to select which of the 12 mode-specific patches you wish to load. The patch number is indicated by the Level LED on the right-of-center pad.

Press the EDIT button (or press either of the two left encoders) to exit mode selection.

- **Assigning Pads in Combo Mode:** If Tetrapad is currently operating in Mode 1: Combo Mode (See [Combo Mode](#) for more information), then a short press of this button enables the Pad Assignment feature.

Each pad can be assigned a different function using its corresponding encoder, and a small animation plays within each of the four pads to indicate which function is assigned to each pad.

Press the EDIT button again to exit Pad assignment.

7. Shift Button & LED





Some modes offer additional feature sets, which are accessed by pressing the Shift Button. For example, when a pad is assigned to an LFO in Combo Mode, the Shift button switches between Performance and Edit views. See the individual mode discussions to learn whether or not the Shift button is used, and what function it serves. The LED immediately above the Shift button glows red whenever a shift feature is engaged.

8. Outputs 1-8

Outputs CV, pitch, gate or trigger signals depending on the active mode. See the [Modes](#) section to learn the function of each jack in each mode.

9. Output Status LEDs

In general, the color of these LEDs glow solid and indicate the type of signal appearing at the output jack for the active mode:

	Blue	Pitch CV
	Magenta	Gate/Trigger
	Green	Positive Voltage (May indicate vertical position or LFO level)
	Red	Negative Voltage (May indicate vertical position or LFO level)
	Cyan	Pressure

When using Tetrapad, an Output Status LED's brightness (as well as its color) can provide useful status information. For example, a green (vertical position) LED gets brighter when your finger is higher up the pad; a cyan (pressure) LED gets brighter the harder you press a pad; Other modes make additional use of these status LEDs, and will be discussed in the corresponding sections.

Modes Overview

We designed Tetrapad to provide you with tactile control of your modular synth, plus the ability to maximize the flexibility with which you wield that control. For this reason, Tetrapad is a mode-based control surface. Each mode reassigns the four touch pads, four rotary push encoders, eight outputs, numerous status LEDs and shift button.

Tetrapad has three types of modes:

- **Mode 1: Combo Mode** — Combo Mode enables you to assign a unique function to each pad and its pair of associated outputs. In Combo Mode, you can have different pads perform different functions (i.e. one pad might be an LFO, one might be a pair of switches; and two more might be assigned as faders).
- **Modes 2-6: Single Function Modes** — Single function modes simultaneously configure all four pads and the eight outputs to perform a single task (such as turning Tetrapad into a keyboard, chord generator or voltage storage device).
- **Mode 12: Configuration Mode** — Configuration mode is used for setting various Tetrapad preferences, or performing calibration routines.

Combo Mode

In Combo Mode, each of the four pads can be assigned a function independent of the other three pads. These functions (described in detail in [Mode 1: Combo Mode](#)) are:

- **Unipolar Fader** - A Unipolar Fader converts the pad into a pressure and position sensitive fader. Slide your finger up and down the pad to operate it as a virtual fader — with the bottom position sending 0V to the pad's left output and the top position sending 5V. You can choose whether the fader is latched or unlatched, and you can slew between fader levels. In addition, pressing down on a fader sends an additional control voltage to the pad's right output.
- **Bipolar Fader** - A Bipolar Fader converts the pad into a pressure and position sensitive fader (much like the unipolar fader), only its null (0V) position is in the center of the pad. Bipolar faders thus act somewhat like a traditional pitchbend wheel, transmitting positive voltages to the pad's left output when your finger is above the midpoint, and negative voltages when your finger is below the midpoint. You can choose whether the fader is latched or unlatched, and you can slew between fader levels. In addition, pressing down on a fader sends an additional control voltage to the pad's right output.
- **Drum** - A Drum Pad generates a gate signal when touched (which is sent to the pad's left output), plus a second CV based on the vertical position of your finger (sent to the pad's right output). Since each pad generates a gate no matter where you tap it, this mode is ideal for "finger" drumming, but with the possibility of additional expression via the positional output CV.
- **Switches** - When assigned as a Switch, a single pad becomes two independent switches — one on the top half of the pad (whose value appears at the pad's left output); and one on the bottom half of the pad (whose value appears at the pad's right output). The two switches can be configured to act either as latched toggle switches or as momentary switches.
- **LFO** - When assigned as an LFO, a single pad becomes a controller for a Low Frequency Oscillator (LFO), which appears at the pad's left output. Using a combination of the pad itself, plus the Shift button and encoders, you can set the LFO rate, waveshape, polarity and other LFO attributes and control them in real time. In addition, the pad responds to pressure, which it sends to the pad's right output for additional modulation options.

Single Function Modes

- **Mode 2: Voltages Mode** - Voltages Mode divides each pad into two regions — an upper and a lower — giving you access to 8 voltage banks, each of which can store 8 voltages (one for each output).
- **Mode 3: Keyboard Mode** - Keyboard Mode turns Tetrapad into an 8-key keyboard, with each key capable of sending a different note to Outs 1-4. This mode divides each of the four pads in two, creating an upper key and a lower key. Touching any pad also outputs both a trigger and a gate signal, and pads respond to both position and pressure. You define notes for each key by selecting a keyboard mapping from the built-in Scale Library and you set a root note with a twist of an encoder. Diatonically shifted versions of the root scale appear at each of the four outputs and you can rotate these assignments using another encoder.
- **Mode 4: Custom Keyboard Mode** - Custom Keyboard Mode is similar to Keyboard Mode (described above), only instead of automatically assigning keys to a particular scale, you manually assign a note to each of the eight keys (and for each of the four outputs, if you wish). Custom Keyboard Mode is for people who want direct control over the pitch of every key and output, and don't wish to be constrained by the scales included in Mode 3's Scale Library.
- **Mode 5: Chord Mode** - Chord Mode stores a unique 4-note chord for each of the four pads. Touching a pad transmits the four notes to the first four outputs, enabling you to play one-finger chords (if you use multiple oscillators). Touching any pad also outputs both a trigger and a gate signal, and pads respond to both position and pressure. Define a chord for each pad by selecting it from the built-in Chord Library, and alter the root note, inversion and chord rotations using the encoders.
- **Mode 6: Custom Chord Mode** - Custom Chord Mode is similar to Chord Mode (described above), only instead of using the encoders to select chords, roots, inversions and rotations, you manually assign — pad-by-pad and output-by-output — each note in each chord. Custom Chord Mode is for people with chord requirements that extend beyond those included in Mode 8's Chord Library.

Configuration Modes

In addition to the various single function and combo modes mentioned previously, there is a special global configuration mode, plus a hidden Output Calibration mode.

- **Mode 12: Global Configuration** - This is a “special” mode for configuring Tetrapad’s pressure response to match your own preferences. Unlike the other modes, Global Configuration mode is not meant for performance nor for controlling other modules.
- **Hidden Calibration Mode** - Use of this mode requires caution (not to mention an accurate voltage meter), since it allows you to fine-tune the 8 output voltages. Tetrapads are calibrated at the factory prior to shipment, so it’s unlikely you’ll ever need to do this. But should the need ever occur, the procedure is outlined at the end of this manual.

Selecting Modes & Loading a Mode Preset

LED color shows output signal type for the selected Mode

- GREEN: Height
- CYAN: Pressure
- BLUE: Pitch
- PURPLE: Gate/Trig
- ORANGE: Voltage

1. Long-hold the WHITE button (>1 sec) to engage Mode & Preset selection.
2. Use the encoders (as indicated on this page) to select the mode and preset you wish to load (or save).
3. Press the WHITE button to exit Mode & Preset selection, returning Tetrapad to normal operation.

MODES & PRESETS

Turn either of the two left encoders (1 or 2) to select the MODE number. (indicated by the LED ladder beneath the left-center pad)

Press either encoder to load the indicated (bright LED) MODE and exit Mode & Preset selection.

Tetrapad

intellijel

Turn either of the two right encoders (3 or 4) to select the PRESET. (indicated by the LED ladder beneath the right-center pad)

Press **encoder 3** to LOAD the indicated (bright LED) PRESET. Press **encoder 4** to SAVE the current pad configuration to the indicated (bright LED) preset slot.

Visual indication of MODE

Mode number indicated by LED ladder beneath the pad.

Bright RED: Mode number as selected by encoders **1** or **2**

This is the mode that will load when you press either encoder or when you press the WHITE button to exit Mode & Preset Selection.

Dim RED: Currently active mode number. Will be replaced by encoder-selected mode.

Visual indication of PRESET

Preset number indicated by LED ladder beneath the pad.

Bright RED: Preset number as selected by encoders **3** or **4**

This is the preset that will LOAD when you press **encoder 3**, or SAVE when you press **encoder 4**.

Dim RED: Active preset prior to loading or saving a new preset.

To select different modes on Tetrapad, and load one of the mode's twelve associated presets:

1. Long-press (>1 second) the white EDIT button to enter Mode Selection.
2. Rotate either of the two left encoders to select the desired mode.

A brightly lit Level LED embedded beneath the left-center pad will move up or down the pad as the encoder is rotated. A dimly lit Level LED shows which mode Tetrapad was in when you entered Mode Selection.

Use the Level Labels in the middle of the Tetrapad to see the actual mode number of the correspondingly lit Level LED. For example, if the bright Level LED next to Level Label 2 is lit on the left-of-center pad, then you're selecting Mode 2; etc.

Note that the eight Output Status LEDs will change colors as you cycle through the modes. These colors indicate what type of signal appears at each output for each mode, and will be discussed further in the mode-specific sections of this manual.

3. Rotate either of the two right encoders to select the desired preset within the selected mode.

Each mode has 12 preset "slots," as indicated by the Level LEDs embedded beneath the right-center pad. As you rotate one of the two right encoders, the brightly lit Level LED moves up/down accordingly, to indicate which of the 12 presets you're about to load. The dimly lit LED indicates the location of the last used Mode Preset.

NOTE: Each mode you select remembers that last preset used by that mode. So you only need to select a Mode Preset if you want to use one that's different than the preset you used the last time you selected that mode.

4. Press Encoder 3 to load the Mode Preset into Tetrapad.
5. Press the white EDIT button to exit mode selection.

Your Tetrapad will now operate in this mode, using the selected preset. Note that you can also click either of the two left encoders to exit mode selection.

Saving Mode Presets

To save your current configuration to one of the twelve mode-specific presets:

1. Configure your pads as desired.

For example, assume you're in Combo Mode and you configure Pad 1 and 2 to be unipolar faders, Pad 3 to be an LFO and Pad 4 to be a pair of switches, and you want to save this configuration for future use.

2. Long-press (>1 second) the white EDIT button to enter Mode Selection.

Tetrapad will enter Mode Selection with the current mode already selected.

3. Rotate either of the two right encoders to select the preset slot in which you want to save your configuration.

4. Press Encoder 4 to Save the configuration as a mode preset.

The four pad status LEDs will light green as the preset is being saved.

5. Press the white EDIT button to exit mode selection.

Auto-Saving

Tetrapad retains all mode settings while powered on — thus ensuring that you can switch freely between modes in a performance, knowing that when you return to a mode, it will always be exactly as you left it.

In addition, Tetrapad remembers many of its settings when powered off. Specifically, it remembers all the critical configuration parameters for each mode (for example: slew rates; note assignments in keyboard mode; voltages in voltage mode; chord assignments in chord mode; etc) but it does not retain settings that might be specific to a performance, such as: fader values; LFO speeds; most-recently touch key or pad; etc).

By default, Tetrapad automatically saves its settings every minute, or whenever you change modes. This makes Tetrapad ideal for live performance, since it will always power up with your carefully configured modes still intact and ready to perform.

Mode Reset

In spite of the obvious advantages gained by Tetrapad's Auto-Save feature, you may sometimes prefer to program a mode "from scratch" rather than modifying a previously saved configuration. For this reason, Tetrapad provides a Mode Reset feature:

1. Long-press (>1 sec) the white EDIT button to enter Mode Selection, and rotate either of the two left encoders to select the mode you wish to reset.
2. Press the red Shift button and, while holding it down, exit Mode Selection (by clicking either the white EDIT button or either of the two left push encoders).

Tetrapad resets that mode and its twelve presets to the factory default settings.

NOTE: You can also reset all Modes simultaneously (along with the Global Configuration Settings) by using this same technique with Mode 12 selected.

Mode 1: Combo Mode

Combo Mode enables you to assign a unique function to each pad and its pair of associated outputs. In Combo Mode, you can have different pads perform different functions (i.e. one pad might be an LFO, one might be a pair of switches; and two more might be assigned as faders).

To Select Combo Mode:

1. Long-press (>1 sec) the white EDIT button to enter Mode selection.
2. Rotate either of the two left encoders to select Mode 1.

A brightly lit Level LED embedded beneath the left-center pad will move up or down the pad as the encoder is rotated — the lowest LED corresponds to Mode 1, and the highest to Mode 12.

3. Rotate either of the two right encoders to select which of the twelve Mode Presets you wish to load.
4. Press Encoder 3 to load that Mode Preset into Tetrapad.

NOTE: Every time you enter Mode Selection and select a Mode, Tetrapad automatically selects the most recently used Mode Patch. So if you want to load the same Preset that you last used with the mode, you can skip the Preset selection step.

5. Press the white EDIT button (or either of the two left encoders) to exit Mode selection.

Once in Combo Mode, you can assign different functions to different pads. The following sections discuss each of the pad assignment options available in Combo Mode.

Combo Mode: Unipolar Fader

A unipolar fader converts a pad into a pressure and position sensitive fader. Slide your finger up and down the pad to operate it as a virtual fader — with the bottom position sending 0V to the pad's left output, and the top position sending 5V. You can choose whether the fader is latched or unlatched, and you can slew between fader levels. Finger pressure sends an additional control voltage to the pad's right output.

Rotate the encoder while holding the red SHIFT button to set a Slew Rate for the fader

This is the rate at which fader values change from one level to the next.

Clockwise rotation increases the slew, allowing for gradual changes.

Counterclockwise rotation decreases the slew, ultimately enabling instantaneous changes between fader levels (or tight tracking of finger movements on the fader).

**COMBO MODE:
UNIPOLAR FADER PAD**

Visual indication of output voltage:

- **Fader Position Level**
Brightness = a higher positive voltage.
- **Pressure Level**
Brightness = a higher positive voltage.

Slew Rate

Press and hold while turning the encoder to set the fader's slew rate.

VERTICAL Position
CV Out

PRESSURE
CV Out

↓ **Turn Latch Mode On/Off**

Fader Is Latched

Fader Is Not Latched

Slew Rate (if unlatched)
RED = more slew

Slew Rate (if latched)
PURPLE = more slew

In Use:

Level LEDs display fader value with 0V at the bottom.

Latched faders remain at the touched level when your finger is lifted.

Unlatched faders return to the bottom (zero) when your finger is lifted.

Values slew (ramp up/down) between touched levels at a rate set by holding the red SHIFT button and turning the encoder.

Pad Assignment Indicator:

A Unipolar Fader pad is indicated by a single dimly lit LED at the bottom of the pad.

Animation (when assigning a pad):

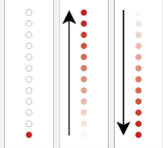



Assigning Unipolar Fader Functionality To A Pad

To assign unipolar fader functionality to one of Tetrapad's four pads:

1. Put Tetrapad into Combo Mode, as described in the [Combo Mode](#) section, earlier.
2. Short-press (<1 sec) the white EDIT button.

The Level LEDs embedded beneath each pad will play an animation, indicating the function currently assigned to each pad.

3. Rotate the encoder that corresponds to the pad you wish to make a Unipolar Fader.
4. Stop rotating when the Unipolar Fader animation plays (as shown in the previous pictograph).
5. Press the white EDIT button to exit Pad assignment, and to use your Tetrapad.

The bottom LED is lit on the assigned pad, indicating that it will now function as a Unipolar Fader (also shown in the previous pictograph).

Using Unipolar Faders

1. Slide a finger up and down a pad, just as if you were moving an actual fader.

Alternately, you can simply tap a pad anywhere along its vertical scale and the fader will jump to that level directly (using a slew rate you define, as discussed shortly). Faders return to their null values when you lift your finger (unless you latch the fader by pressing the pad's encoder).

Tetrapad sends a fader's vertical position CV to its left (odd numbered) output. The Output Status LED lights green to represent the presence of a CV signal, while the brightness of the LED indicates its absolute value, from 0 to +5V.

2. Press down on a pad to send an additional pressure-sensitive CV to the pad's right (even numbered) output.

The Output Status LED lights cyan to represent the presence of a pressure CV signal, while the brightness of the LED indicates its absolute value, from 0 to +5V.

3. If you want to latch the fader, press the pad's encoder.

Latched faders are indicated by a blue Pad Status LED. When a fader is latched, it remains at the last level touched — much like a real fader on an analog mixing console. When a fader is unlatched (the Status LED is off), it snaps back to its null value when you release it — much like the spring-loaded modulation wheel used by some synths.

Slew Between Fader Settings

If you prefer to tap a fader (rather than drag it) or if you use latch mode, you'll appreciate the ability to set the rate at which fader values move from one touched level to the next.

1. Hold down the red SHIFT button and rotate the pad's encoder to set its slew rate.

Clockwise turns increase the time it takes to move from one fader value to another. Counterclockwise turns decrease the amount of time it takes to move from one fader value to another (down to "instantaneous").

Slew times are indicated by a red Pad Status LED above the fader — with an LED glowing increasingly brighter as the slew gets longer. Since latched faders cause the Pad Status LED to turn blue, slew rates applied to a latched fader cause increasing amounts of red to mix with the blue LED, ultimately resulting in a purple LED at maximum slew rate.

Combo Mode: Bipolar Fader

A bipolar fader converts a pad into a pressure and position sensitive fader (much like a unipolar fader), but with its null (0V) position in the center of the pad. This means it transmits positive voltages to the pad's left output when touched above the midpoint, and negative voltages when touched below the midpoint. You can choose whether the fader is latched or unlatched, and you can slew between fader levels. In addition, pressing down on a fader sends an additional control voltage to the pad's right output.

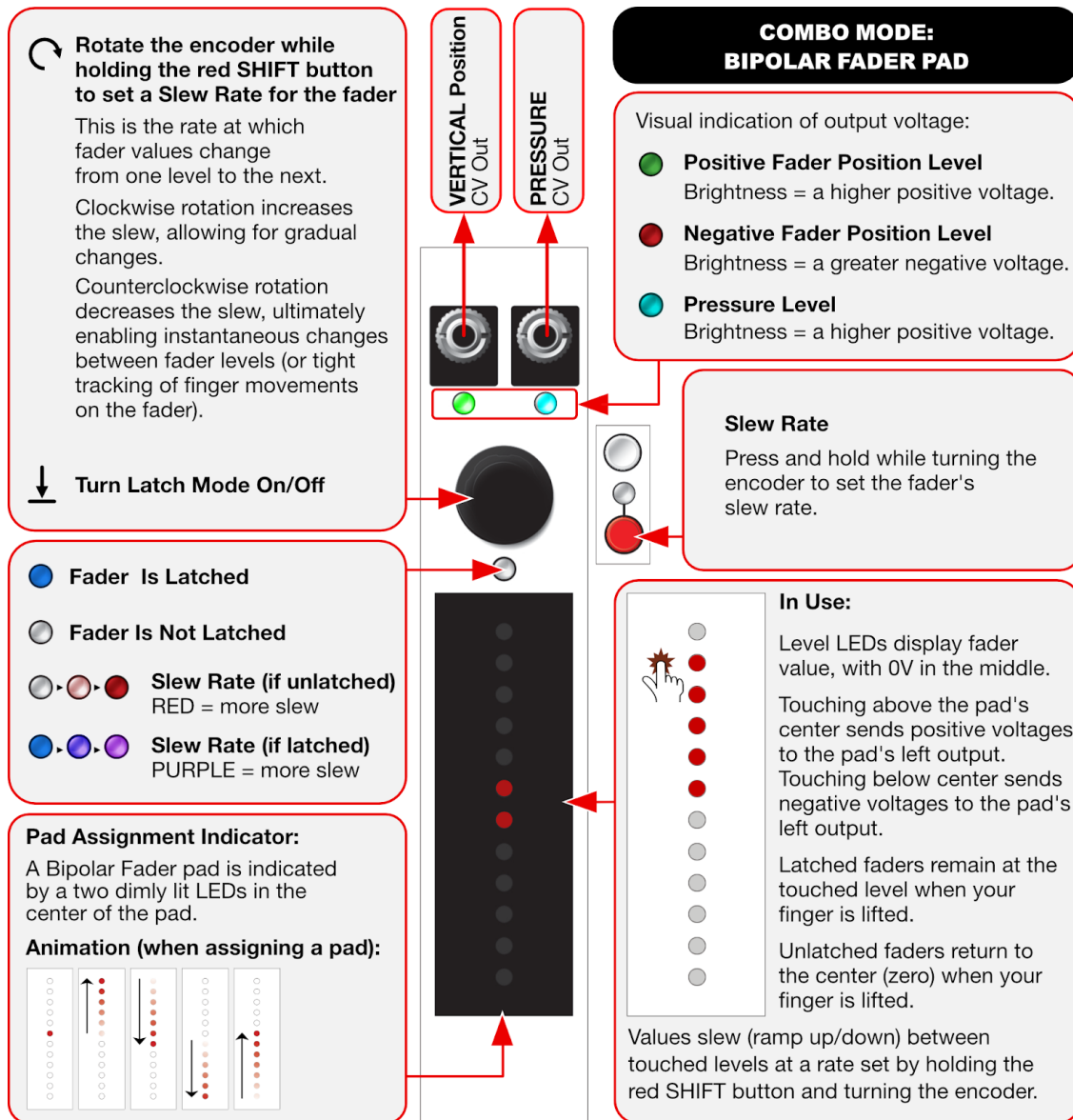

Assigning Bipolar Fader Functionality To A Pad

To assign bipolar fader functionality to one of Tetrapad's four pads:

1. Put Tetrapad into Combo Mode, as described in the [Combo Mode](#) section, earlier.
2. Short-press (<1 sec) the white EDIT button.

The Level LEDs embedded beneath each pad will play an animation, indicating the function currently assigned to each pad.

3. Rotate the encoder that corresponds to the pad you wish to make a Bipolar Fader.
4. Stop rotating when the Bipolar Fader animation plays (as shown in the previous pictograph).
5. Press the white EDIT button to exit Pad assignment, and to use your Tetrapad.

The two middle LEDs are lit on the assigned pad, indicating that it will now function as a Bipolar Fader (also shown in the previous pictograph).

Using Bipolar Faders

1. Slide a finger up and down a pad, just as if you were moving an actual fader.

Alternately, you can simply tap a pad anywhere along its vertical scale and the fader will jump to that level directly (using a slew rate you define, as discussed shortly). Faders return to their null values when you lift your finger (unless you latch the fader by pressing the pad's encoder).

Tetrapad sends a fader's vertical position CV to its left (odd numbered) output. If you touch the pad above center, the Output Status LED lights green (indicating a positive voltage). If you touch the pad below center, the Output Status LED lights red (indicating a negative voltage). The brightness of the LED indicates the absolute value of the voltage.

2. Press down on a pad to send an additional pressure-sensitive CV to the pad's right (even numbered) output.

The Output Status LED lights cyan to indicate the presence of a pressure CV signal, while the brightness of the LED indicates its absolute value, from 0 to +5V.

3. If you want to latch the fader, press the pad's encoder.

Latched faders are indicated by a blue Pad Status LED. When a fader is latched, it remains at the last level touched. When a fader is unlatched (the Status LED is off), it snaps back to its minimum value when you release it.

Slew Between Fader Settings

If you prefer to tap a bipolar fader (rather than drag it) or if you use latch mode, you'll appreciate the ability to set the rate at which fader values move from one touched level to the next.

1. Hold down the red SHIFT button and rotate the pad's encoder to set its slew rate.

Clockwise turns increase the time it takes to move from one fader value to another. Counterclockwise turns decrease the amount of time it takes to move from one fader value to another (down to "instantaneous").

Slew times are indicated by a red Pad Status LED above the fader — with an LED glowing increasingly brighter as the slew gets longer. Since latched faders cause the Pad Status LED to turn blue, slew rates applied to a latched fader cause increasing amounts of red to mix with the blue LED, ultimately resulting in a purple LED at maximum slew rate.

Combo Mode: Drum Pad

A drum pad generates a gate signal (left pad output) when the pad is touched, plus a second CV (right pad output) based on the vertical position of your finger. Since the pad generates a gate no matter where you tap it, it's ideal for triggering drum modules. The pad's right output provides an additional source of position-based modulation, which you can connect to a drum module's velocity or accent input, or anything else that benefits from CV control.

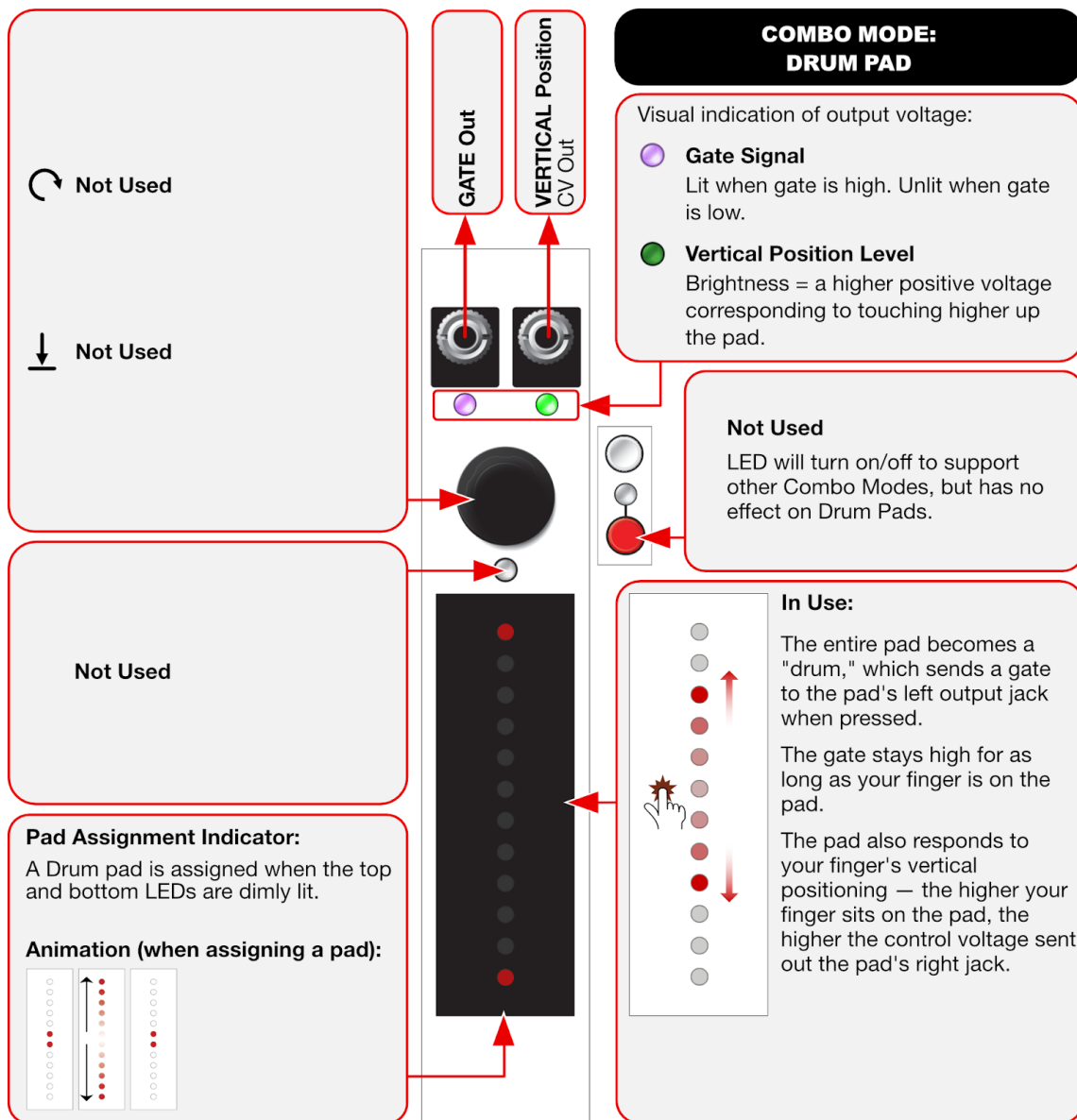

Assigning Drum Pad Functionality To A Pad

To assign Drum Pad functionality to one of Tetrapad's four pads:

1. Put Tetrapad into Combo Mode, as described in the [Combo Mode](#) section, earlier.
2. Short-press (<1 sec) the white EDIT button.

The Level LEDs embedded beneath each pad will play an animation, indicating the function currently assigned to each pad.

3. Rotate the encoder that corresponds to the pad you wish to make a Drum Pad.
4. Stop rotating when the Drum Pad animation plays (as shown in the previous pictograph).
5. Press the white EDIT button to exit Pad assignment, and to use your Tetrapad.

The top and bottom LEDs are lit on the assigned pad, indicating that it will now function as a Drum Pad (also shown in the previous pictograph).

Using Drum Pads

1. Tap a pad to send a gate signal to the pad's left (odd numbered) output.

The output's Status LEDs glows magenta, indicating it's a gate output.

2. Slide a finger up and down the pad to generate an additional position-sensitive CV from the pad's right (even numbered) output.

The output's Status LED glows green to represent the presence of a position-based CV signal, while the brightness of the LED indicates its absolute value.

TIP: Although the positional CV generates continuous voltages as you slide your finger up and down the pad, you might find it particularly useful to patch this output into a drum module's accent or velocity input. In this way, you control a drum's velocity value by how high you tap a pad, adding additional nuance and control to your drum performance.

Combo Mode: Switches

When designated as a switch, a single pad becomes two independent switches — one on the top half of the pad (whose value appears at the pad's left output); and one on the bottom half of the pad (whose value appears at the pad's right output). The two switches can be configured to act either as latched toggle switches or as momentary switches.

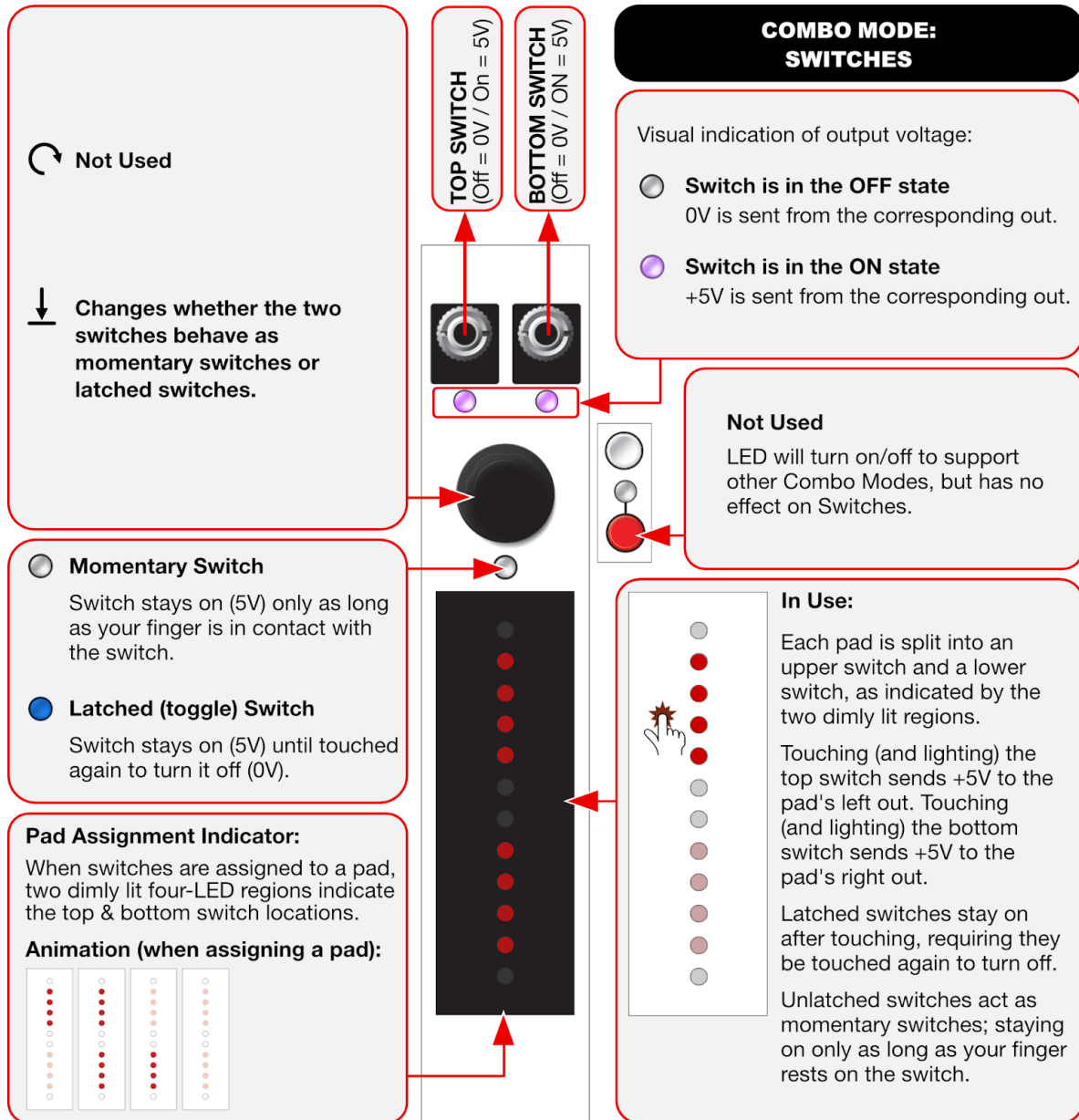

Assigning Switches Functionality To A Pad

To assign Switches functionality to one of Tetrapad's four pads:

1. Put Tetrapad into Combo Mode, as described in the [Combo Mode](#) section, earlier.
2. Short-press (<1 sec) the white EDIT button.

The Level LEDs embedded beneath each pad will play an animation, indicating the function currently assigned to each pad.

3. Rotate the encoder that corresponds to the pad you wish to make a Switch.
4. Stop rotating when the Switch animation plays (as shown in the previous pictograph).
5. Press the white EDIT button to exit Pad assignment, and to use your Tetrapad.

Two four-LED segments are lit on the assigned pad — one segment on the top; and one on the bottom — indicating that it will now function as a pair of Switches (also shown in the previous pictograph)

Using Switches

1. Touch a switch to send +5V to the corresponding Out jack.

Each pad is divided into two switches — one assigned to the top half of a pad, and the other assigned to the bottom.

The top switch controls the pad's left (odd numbered) output. The bottom switch controls the pad's right (even numbered) output.

Four LEDs light beneath the surface of the pad indicating which switch is currently active. When a switch is "on," the four switch indicator LEDs light brightly. When off, the indicator LEDs glow dimly.

2. Press the pad's encoder to change whether the two switches on the corresponding pad act as *momentary* switches or *toggle* switches.

Toggle switches stay on until you press them again to turn them off.

Momentary switches stay on only as long as your finger is on the switch. Removing your finger automatically turns the switch back off.

In both cases, the Output Status LEDs indicates whether the switch is currently on (+5V = lit) or off (0V = off).

Combo Mode: LFO

When assigned as an LFO, a single pad becomes a controller for a built-in Low Frequency Oscillator (LFO), which appears at the pad's left output. Using a combination of the pad itself, plus the shift button and encoders, you can set the LFO rate, waveshape, polarity and other LFO attributes and control them in real time. In addition, the pad responds to pressure, which it sends to its right output for additional modulation options.

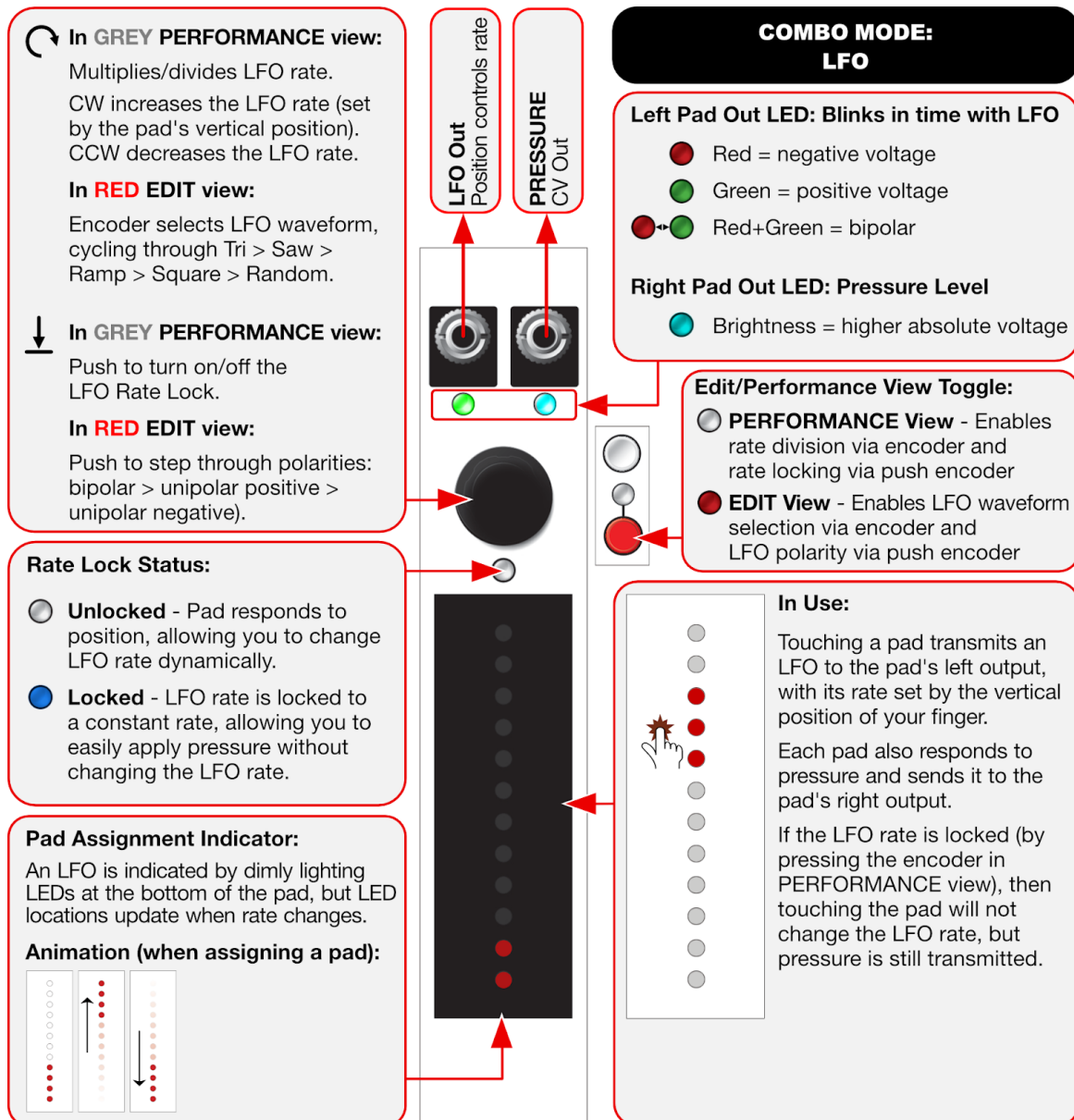

Assigning LFO Functionality To A Pad

To assign LFO functionality to one of Tetrapad's four pads:

1. Put Tetrapad into Combo Mode, as described in the [Combo Mode](#) section, earlier.
2. Short-press (<1 sec) the white EDIT button.

The Level LEDs embedded beneath each pad will play an animation, indicating the function currently assigned to each pad.

3. Rotate the encoder that corresponds to the pad you wish to make an LFO.
4. Stop rotating when the LFO animation plays (as shown in the previous pictograph).
5. Press the white EDIT button to exit Pad assignment, and to use your Tetrapad.

A grouping of three LEDs are lit on the assigned pad, indicating that it will now function as an LFO (also shown in the previous pictograph).

Using an LFO (Overview)

When a pad is designated as an LFO, its left (odd numbered) output transmits a programmable LFO, the rate of which is shown by the Output Status LED that pulses in time with the LFO (and which indicates its polarity).

LFO rate is controlled by your finger's vertical placement on the pad — the higher you touch, the faster the LFO. Finger pressure is sent to a pad's right (even numbered) output.

Pads assigned to LFOs operate in one of two views (which you switch between by pressing the red SHIFT button):`

- PERFORMANCE View (Status LED is OFF) - In this view, pressing the encoder locks/unlocks the current LFO rate, meaning subsequent touches don't change the LFO rate. This allows you to set a rate, lock it, then use pressure without inadvertently changing the LFO rate.
- EDIT View (Status LED is RED) - In this view, pressing the encoder changes the LFO polarity, cycling between bipolar; unipolar (positive); and unipolar (negative) with each press. Rotating the encoder changes the LFO shape, cycling through Triangle, Sawtooth, Ramp (inverse saw), Square and Random shapes.

Using LFO EDIT View

1. If the Shift Status LED is currently off, push the SHIFT Button to light the red LED above it, turning on EDIT View.
2. Adjust the LFO rate by touching its pad.

The higher up you touch a pad, the faster the LFO rate, which is indicated by the rate at which its Output Status LED flashes.

3. Select the LFO shape by rotating the encoder.

This cycles the LFO shape between Triangle, Sawtooth, Ramp (inverse saw), Square and Random.

4. Set the LFO's polarity by pressing the encoder.

Each press of the encoder cycles through the three LFO polarities: bipolar; unipolar (positive only); unipolar (negative only).

You can tell an LFO's polarity by monitoring the Output Status LEDs: A bipolar LFO will switch between green & red. A positive unipolar wave will switch between green & off. A negative unipolar wave will switch between red & off.

5. Press harder on a pad to send an additional pressure-sensitive CV to the corresponding Even numbered output.

Using LFO PERFORMANCE Mode

1. If the Shift Status LED is currently red, push the SHIFT Button to turn it off, enabling PERFORMANCE View:

In LFO PERFORMANCE View, the LFO uses the waveshape and polarity defined in LFO EDIT View. So if you want to modify either of those values for an LFO, you need to temporarily switch back into LFO EDIT View.

2. As in LFO EDIT View, adjust the LFO rate by touching the pad.

The higher up you touch the pad, the faster the LFO rate — which is indicated by the rate at which its Output Status LED flashes.

3. Rotate the encoder to change the pad's LFO rate range.

Each counter-clockwise rotation divides the LFO rate in half, creating longer (slower) oscillations. Each clockwise rotation doubles the LFO rate, creating faster oscillations. There are eight LFO rate range settings available.

4. Press the encoder to lock the LFO rate at its current value.

The corresponding Pad Status LED turns blue, indicating the LFO rate is locked. Now when you touch a pad, the value does not change. This is particularly useful when you want to use the pads to transmit pressure CV without accidentally affecting the LFO rate.

To unlock an LFO, simply press the encoder again, turning off its blue Pad Status LED.

Mode 2: Voltages Mode

Long-press (>1 sec) the white EDIT button to enter Mode selection. Rotate either of the two left encoders to select Mode 2 (as indicated by the position of the brightest Level LED beneath Pad 2). If desired, rotate either of the two right encoders to select one of twelve Mode Presets (indicated by Pad 3), then press Encoder 3 to load your selection. Press the white EDIT button (or either of the two left encoders) to exit Mode selection.

⤵ If SHIFT LED is **GREEN**: Encoders 1 - 4 assign voltages to Outs 1 - 4.
If SHIFT LED is **RED**: Encoders 1 - 4 assign voltages to Outs 5 - 8.

Rotate without your finger on a pad to increment or decrement the associated output voltage.

Rotate with your finger on a pad to randomize the associated output voltage.

⬇ Press an encoder while holding your finger to one of the 8 virtual buttons to reset its corresponding Output voltage to 0V.

⦿ Slew Time (brighter = slower)

Changes which OUTPUT each encoder programs:

- Encoders 1-4 = OUTS 1-4
- Encoders 1-4 = OUTS 5-8

RANDOM: Hold your finger on one of the 8 virtual buttons while pressing SHIFT to randomize all 8 output voltages for that button.

SLEW: Press & hold SHIFT while turning Encoder 1 to set a slew time between voltage changes.

Visual indication of output voltage:

- Positive voltage. Brightness represents a greater absolute voltage.
- Negative voltage. Brightness represents a greater absolute voltage.

In Use:

- Each pad is split into an upper button and a lower button, as indicated by the two lit regions.
- Each button sends its own set of voltages to the 8 outs.
- If an output is slewed, then pressure can control the rate. Specifically, pressing harder on a button quickens the rate of change.

Tetrapad

Out 1 Voltage (x8) Set w/encoders Out 2 Voltage (x8) Set w/encoders Out 3 Voltage (x8) Set w/encoders Out 4 Voltage (x8) Set w/encoders Out 5 Voltage (x8) Set w/encoders Out 6 Voltage (x8) Set w/encoders Out 7 Voltage (x8) Set w/encoders Out 8 Voltage (x8) Set w/encoders

1 2 3 4 5 6 7 8

12 B
11 A#
10 A
9 G#
8 G
7 F#
6 F
5 E
4 D#
3 D
2 C#
1 C

intellijel

Voltages Mode divides each pad into two regions — an upper and a lower — giving you access to 8 stored voltages per output! That's right, each of Tetrapad's eight outputs has its own bank of 8 virtual buttons, each of which can store a voltage value specifically for that output, meaning you have 64 voltage storage locations in total.

Imagine pushing a single button that sends one voltage to a filter's frequency, another voltage to resonance, a third to a Quadra Expander's attack CV and a fourth to its decay CV. You could use the fifth output to change waveshapes on a Shapeshifter, and the sixth to set the amount of wave folding. Output 7 could change the grain size in Rainmaker, while Out 8 could adjust its wet/dry mix. In other words, used this way, Voltages Mode is almost like having patch memory within Eurorack.

Using Voltages Mode

4) The voltage for each output is set by rotating an encoder.
 Encoders 1-4 set voltages for Outs 1 - 4 when Shift LED is GREEN (●).
 Encoders 1-4 set voltages for Outs 5 - 8 when Shift LED is RED (●).
 Toggle between GREEN and RED states by pressing the SHIFT button.

5) Relative voltage levels are indicated by each Output Status LED, where:
 ● RED = negative voltage. The brighter the LED, the greater the amount.
 ● GREEN = positive voltage. The brighter the LED, the greater the amount.

1) Each of Tetrapad's four pads is divided into two halves: an upper and a lower, which results in eight buttons...

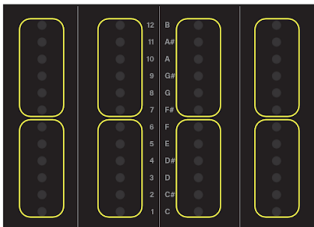

2) ...Touching one of the eight buttons lights it...

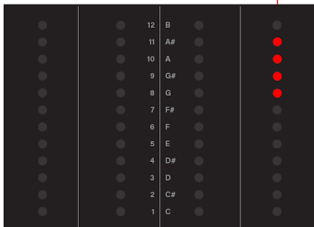

3) ... and sends up to 8 memorized voltages to the 8 outputs.

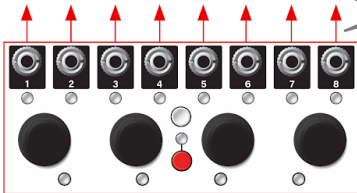

Each pad is divided into two regions: an upper and a lower, meaning you have eight voltage storage locations, each accessed by its own virtual “button.”

1. Touch one of the eight virtual buttons to transmit up to eight different voltage values from each of Tetrapad's eight outputs.

Notice that a group of four Level LEDs light on the pad, indicating which virtual button you just touched.

Edit a Button's Stored Voltages

1. Touch one of Tetrapad's eight virtual buttons to select it for editing (each of the four pads is divided into two regions: an upper half and a lower half, giving eight virtual buttons).
2. To assign voltages to Outputs 1 - 4, make sure the Shift LED is green, then rotate encoders 1 - 4, which assigns voltages to Outputs 1 - 4 respectively.

NOTE: If the Shift LED is currently red, push the Shift button to toggle it to the green state)

Turning an encoder clockwise assigns increasingly higher positive voltages (up to +5 V), which are indicated by the intensity of the Output Status LED, which glows green to indicate that the voltage is positive.

Turning an encoder counter-clockwise sets increasingly larger negative voltages (up to -5 V), which are indicated by the intensity of the Output Status LED, which glows red to indicate the voltage is negative.

3. To assign voltages to Outputs 5 - 8, make sure the Shift LED is red, then rotate encoders 1 - 4, which assigns voltages to Outputs 5 - 8 respectively.

NOTE: If the Shift LED is currently green, push the Shift button to toggle it to the red state.

Randomize a Single Stored Voltage

Those of you who prefer the serendipity approach to sound design will appreciate Tetrapad's random voltage assignment feature. To randomize a single output voltage:

1. Touch and hold the desired button (do not release your finger from the pad). Then, with your finger still on the virtual button, rotate the encoder assigned to the output you wish to randomize.

For example, if you hold your finger on the top left virtual button while turning Encoder #2, then with each click of the encoder, you will assign a new random voltage to Output 2 (or Output 6 if the Shift LED is red).

Randomize all 8 Stored Voltages for a Button

Those of you who prefer the serendipity approach to sound design and who like it applied judiciously will appreciate this feature, which lets you select a virtual button and randomize all 8 Outputs simultaneously.

1. Touch and hold the desired button (do not release your finger from the pad). Then, with your finger still on the virtual button, press Tetrapad's little red SHIFT button.

A random voltage will be assigned to each of that button's 8 outputs. Each time you press the SHIFT button, you'll generate a new set of 8 output voltages.

Reset a Stored Voltage to 0V

1. Touch and hold the desired button (do not release your finger from the pad). Then with your finger still on the virtual button, press the encoder assigned to the output you wish to reset to 0V.

For example, if you hold your finger on the top left virtual button while pressing Encoder #3, then Output 3 will reset to 0V (or Output 7 if the Shift LED is red).

Slew Between Stored Voltages

Normally, each time you tap a different button, Tetrapad instantly sends the corresponding voltages to the 8 outputs. But Tetrapad also gives you the ability to slew this voltage change — meaning it's possible to “morph” between different collections of stored voltages, resulting in smooth (rather than instantaneous) changes.

1. Press the red Shift button and continue holding it while turning Encoder 1.

Clockwise turns increase the time it takes to move from one voltage value to another (up to a maximum of about a minute to move between min/max levels). Counterclockwise turns decrease the amount of time it takes to move from one fader value to another (down to “instantaneous”).

Slew times are indicated by a red Pad Status LED above each fader — with an LED glowing increasingly brighter as the slew gets longer.

Note that slew time is a global setting within Voltages Mode, meaning the rate of change affects all buttons and all outputs simultaneously.

Slew is pressure-dependent. Press harder on a button to quicken the rate of change between values. The longer the slew, the more noticeable the effect of pressure.

Mode 3: Keyboard Mode

Long-press (>1 sec) the white EDIT button to enter Mode selection. Rotate either of the two left encoders to select Mode 3 (as indicated by the position of the brightest Level LED beneath Pad 2). If desired, rotate either of the two right encoders to select one of twelve Mode Presets (indicated by Pad 3), then press Encoder 3 to load your selection. Press the white EDIT button (or either of the two left encoders) to exit Mode selection.

1: Sets Octave

2: Selects Scale only in **RED** (edit) mode. unused in **GREEN** mode.

3: Selects Root Note only in **RED** (edit) mode. Rotates Outputs only in **GREEN** mode.

4: Inverts Scale

1-4: Resets respective Octave, Scale, Root or Output rotation to its default value.

Keyboard Note Out 1 from Scale Library

Note Out 2: Scale w/+2 diatonic Xpose

Note Out 3: Scale w/+4 diatonic Xpose

Note Out 4: Scale w/+6 diatonic Xpose

Position CV Out from any Pad

Pressure CV Out from any Pad

Trigger Out from any Pad

Gate Out from any Pad

KEYBOARD MODE

(assign notes from a scale library)

Visual indication of output voltage:

- Outs 1-4: Notes
- Out 5: Position (any Pad) Brightness represents a higher absolute voltage.
- Out 6: Pressure (any Pad) (brightness = amount)
- Out 7: Trigger (any Pad)
- Out 8: Gate (any Pad)

Visual indication of octave:

- Higher octaves. (Brightness = oct height, up to 5 octaves above)
- Lower octaves. (Brightness = oct depth, up to 5 octaves below.)

If you hold SHIFT and turn Encoder 1, this LED displays slew rate rather than octave. The longer the slew time, the brighter the LED:

● ● ● ●

Toggles between Edit & Performance Views:

- PERFORMANCE View
- EDIT View

If you press and hold SHIFT while turning Encoder 1, you can set a slew time between notes.

In Use:

B	●
A#	●
A	●
G#	●
G	●
F#	●
F	●
E	●
D#	●
D	●
C#	●
C	●

Each pad is split into two keys: an upper key and a lower key (giving you eight playable keys). Tap a key to play a note. Each key can send a different note value to Outs 1-4.

All Ladder LEDs remain dimly lit on the most recently touched (and active) key.

Keyboard Mode turns Tetrapad into an 8-key keyboard, with each key capable of sending a different note to Outs 1-4. This mode divides each of the four pads in two, creating an upper key and a lower key.

Touching any pad outputs both a trigger and a gate signal, and pads respond to both position and pressure, giving you expressive CV control over anything you want (such as a VCA level or filter frequency).

You define notes for each key by selecting a keyboard mapping from the built-in Scale Library and you set a root note with a twist of an encoder. Diatonically shifted versions of the root scale appear at each of the four outputs and you can rotate these assignments using another encoder.

Using Keyboard Mode

In Keyboard Mode, the pads serve two purposes:

- In PERFORMANCE View: Touch one of the eight keys (each pad is divided into an upper key and a lower key) to send a programmable pitch out each of the four outputs, enabling you to play melodies (or chords) from the Tetrapad. Gate and trigger signals are also output, as well as pressure and position.
- In EDIT View: When the Shift Status LED is red (EDIT view), the middle two pads display the number of the selected scale and the root of that scale.

EDIT VIEW: Assigning Keys According to Scale

Use EDIT View to assign the eight keys to play notes from the built-in Scale Library, and to set that scale's root note.

1. If the Shift Status LED is green, push the SHIFT Button to change its color to red. A red Status LED indicates that Tetrapad is in EDIT View..
2. Touch any of the eight keys.

Each of Tetrapad's four pads is divided into a top half and a bottom half, resulting in eight "keys." When you touch a key, four LEDs light beneath your finger, indicating which key you've pressed.

3. Release the key.

The key's four indicator LEDs will dim (though remain slightly illuminated to indicate the most recently touched key). The brightly lit LED beneath Pad 2 indicates the current scale, and the brightly lit LED beneath Pad 3 represents the root of that scale.

- Turn Encoder 2 to select the desired scale.

Selecting a scale automatically assigns a different note within that scale to a different key. There are 12 built-in scales corresponding to the 12 LEDs on Pad 2. Tetrapad's scale library has the following scales:

Memory	Scale	Intervals
1	Major	0, 2, 4, 5, 7, 9, 11
2	Minor	0, 2, 3, 5, 7, 8, 10
3	Dorian	0, 2, 3, 5, 7, 9, 10
4	Lydian	0, 2, 4, 5, 7, 9, 11
5	Phrygian	0, 1, 3, 5, 7, 8, 10
6	Locrian	0, 1, 3, 5, 6, 8, 10
7	Melodic Minor	0, 2, 3, 5, 7, 9, 11
8	Harmonic Minor	0, 2, 3, 5, 7, 8, 11
9	Super Locrian	0, 1, 3, 4, 6, 8, 10
10	Bhairav	0, 1, 4, 5, 7, 8, 11
11	Hungarian	0, 2, 3, 6, 7, 8, 11
12	Enigmatic	0, 1, 4, 6, 8, 10, 11

Furthermore, selecting a scale assigns it to each of the three additional pitch outputs, but rotates their notes diatonically. This means the notes appearing at Out 2 are diatonically shifted +2; the notes appearing at Out 3 are diatonically shifted by +4; and the notes appearing at Out 4 are diatonically shifted by +6.

- Turn Encoder 3 to set the root note of the scale.

The root note is indicated by the LED position beneath Pad 3.

Keyboard Mode places the root note on the lower half of Pad 1, then maps ascending pitches L-to-R across the bottom of each pad, then L-to-R across the top of each pad, as shown in the following example:

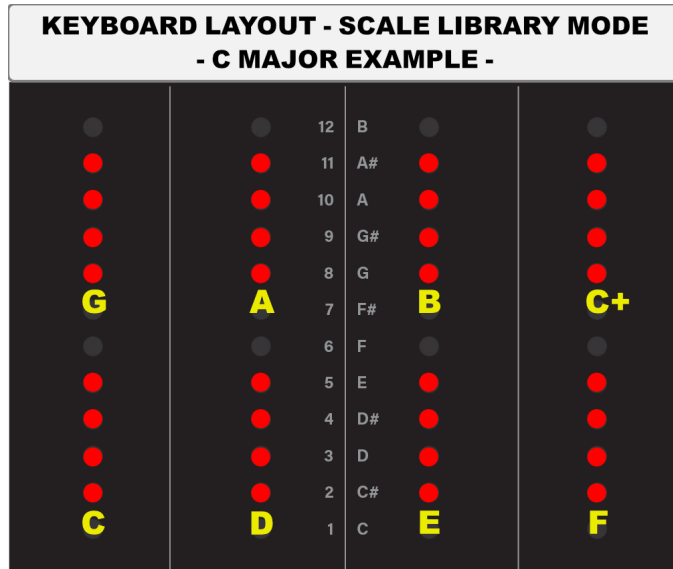

PERFORMANCE VIEW: Playing the Keyboard

1. If the Shift Status LED is red, push the SHIFT Button to change its color to green. A green Status LED indicates that Tetrapad is in PERFORMANCE View.
2. Tap any of the eight keys to send the notes (as assigned in EDIT View, discussed earlier) to Output 1.

In addition, Tetrapad sends diatonically shifted versions of the scale to each of the three remaining outputs. Specifically, Out 2 is diatonically shifted +2; Out 3 is diatonically shifted by +4; and the notes appearing at Out 4 are diatonically shifted by +6.

CV representing the vertical position of your tap on the key is sent to Out 5. CV representing the pressure you apply to any key is sent to Out 6. A trigger signal is sent to Out 7, and a Gate is sent to Out 8.

3. Rotate Encoder 1 to change the octave the keyboard's octave.

Rotate clockwise to increase the octave. Octave settings above the default cause the Pad Status LED to glow green. With each subsequent octave increase, the LED will brighten. Rotate counterclockwise to decrease the octave. Octave settings below the

default cause the Pad Status LED to glow red. With each subsequent octave decrease, the LED will brighten. Tetrapad gives you a 10 octave range.

4. Rotate Encoder 3 to rotate the output assignments.

With each clockwise rotation, the output assignments shift to the right by 1. So if you rotate Encoder 3 one turn clockwise, the unshifted scale will appear at Out 2 (rather than Out 1); the +2 scale moves to Out 3; the +4 scale moves to Out 4; and the +6 scale moves to Out 1.

NOTE: The brightest of the four blue Output Status LEDs indicates which output is currently assigned to the unshifted scale.

5. If you're using Keyboard mode to play multiple oscillators (connected to Outputs 1-4), then you can rotate Encoder 4 to invert the chord that appears at those Outputs.

Clockwise rotation inverts the chord upward; counterclockwise rotation inverts the chord downward. For example, one CW turn transposes Out 1 up one octave; a second CW turn transposes Out 2 up one octave, and so on. Similarly, one CCW turn transposes Out 4 down one octave; etc.

The following flow diagram illustrates these instructions graphically:

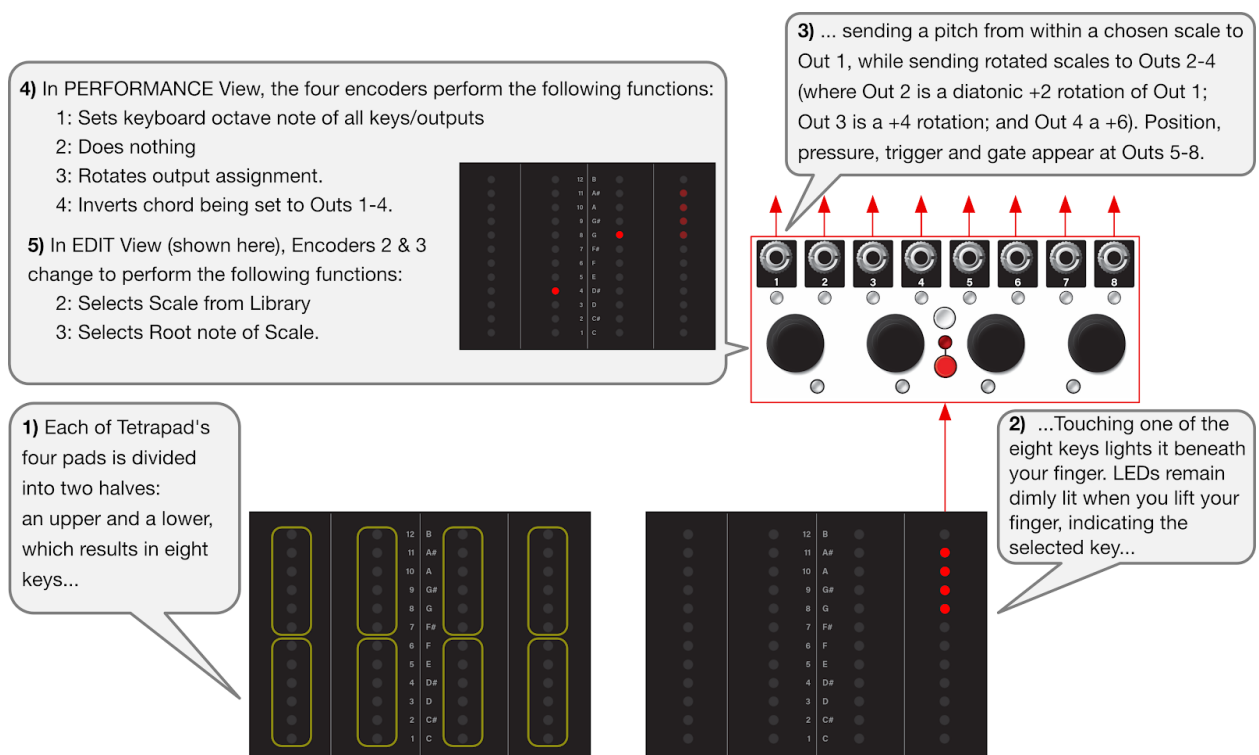

Slew Between Notes

Tetrapad also gives you the ability to slew between notes. To do so, press the red SHIFT button and continue holding it while turning Encoder 1.

Clockwise turns increase the time it takes to move from one note to another (up to a maximum of about 30 sec for a 10 octave glide). Counterclockwise turns decrease the amount of time (down to “instantaneous”).

Slew times are indicated by a red Pad Status LED above each fader — with an LED glowing increasingly brighter as the slew gets longer.

Slew time is a global setting within Keyboard Mode, meaning the rate of change affects all notes equally.

Tuning Mode

Tuning Mode lets you quickly re-configure all four of Tetrapad’s note outputs (1 - 4) to send 0V, and its TRIG and GATE outputs (7 - 8) to send high gate signals. This lets you use Tetrapad as a quick tuning reference for any connected oscillators.

To enter Tuning Mode:

1. Hold down the red SHIFT button, then short-press (<1 sec) the white EDIT button.
The center LED turns blue (indicating Tuning Mode). Outputs 1-4 transmit 0V, and Outputs 7-8 transmit high gate signals.
2. When you’re done tuning your oscillators, repeat the process (i.e. Hold down the red SHIFT button, then short-press (<1 sec) the white EDIT button.
Tetrapad operation returns to normal.

Mode 4: Custom Keyboard Mode

Long-press (>1 sec) the white EDIT button to enter Mode selection. Rotate either of the two left encoders to select Mode 4 (as indicated by the position of the brightest Level LED beneath Pad 2). If desired, rotate either of the two right encoders to select one of twelve Mode Presets (indicated by Pad 3), then press Encoder 3 to load your selection. Press the white EDIT button (or either of the two left encoders) to exit Mode selection.

1: Sets Out 1 Note
2: Sets Out 2 Note
3: Sets Out 3 Note
4: Sets Out 4 Note

(These values are set for each of the 8 keys. You must touch a key to select it for editing.)

1-4: Reset Out to C (0V) for the selected key.

Visual indication of octave:
● Higher octaves. (Brightness = oct height, up to 5 octaves above)
● Lower octaves. (Brightness = oct depth, up to 5 octaves below.)

If you hold SHIFT and turn Encoder 1, this LED displays slew rate rather than octave. The longer the slew time, the brighter the LED:

If you press and hold SHIFT while turning Encoder 1, you can set a slew time between all notes.

Tetrapad

Keyboard Note Out 1 set with Encoder 1
Keyboard Note Out 2 set with Encoder 2
Keyboard Note Out 3 set with Encoder 3
Keyboard Note Out 4 set with Encoder 4
Position CV Out from any Pad
Pressure CV Out from any Pad
Trigger Out from any Pad
Gate Out from any Pad

intellijel

CUSTOM KEYBOARD MODE
(note-by-note entry)

Visual indication of output voltage:
● Outs 1-4: Notes
● Out 5: Position (any Pad) Brightness represents a higher absolute voltage.
● Out 6: Pressure (any Pad) (brightness = amount)
● Out 7: Trigger (any Pad)
● Out 8: Gate (any Pad)

In Use:
Each pad is split into two keys: an upper key and a lower key (giving you eight playable keys).
Tap a key to play a note. Each key can send a different note value to Outs 1-4.
All Ladder LEDs remain dimly lit on the most recently touched (and active) key.

B	●
A#	●
A	●
G#	●
G	●
F#	●
F	●
E	●
D#	●
D	●
C#	●
C	●

Custom Keyboard Mode turns Tetrapad into an 8-key keyboard, with each key capable of sending a different note to Outs 1-4. This mode divides each of the four pads in two, creating an upper key and a lower key.

Touching any pad outputs both a trigger and a gate signal, and pads respond to both position and pressure, giving you expressive CV control over anything you want (such as a VCA level or filter frequency).

Unlike Mode 3, Custom Keyboard Mode lets you define each and every note for each and every pad on all four outputs. This allows for scales and note assignments beyond those included in Mode 3's Scale Library.

Using Custom Keyboard Mode

In Custom Keyboard Mode, the pads serve two purposes:

- As a performance controller: touching one of the eight keys (each pad is divided into an upper key and a lower key) sends a programmable pitch out each of the four outputs, enabling you to play melodies from the Tetrapad. Gate and trigger signals are also output, as well as pressure and position.
- As an edit display: When you touch a key, you select it for editing (as indicated by the four dim LEDs beneath the key's surface). The four pads then display the pitch value assigned to outputs 1-4, which you edit with the corresponding encoders as discussed below.

Manual Note Assignment

1. Touch one of the eight keys to "play it," and to enable it for note assignment.

Each of Tetrapad's four pads is divided into a top half and a bottom half, resulting in eight "keys."

When you touch a key, four LEDs will light beneath your finger, indicating which key you've pressed.

2. Release the key.

The key's four indicator LEDs will dim (though remain slightly illuminated to indicate the most recently touched and editable key).

Notice that beneath the surface of each pad is a single brightly lit LED, whose vertical position indicates the note value that will be sent to the corresponding Output. That is, the bright LED shown beneath Pad 1 represents the note that appears at Out 1; the bright LED shown beneath Pad 2 represents the note that appears at Out 2; etc.

3. Rotate encoder 1 to change the pitch sent to Out 1. If desired, rotate encoders 2-4 to change pitch assignments for outputs 2-4.

When you set a pitch that's an octave higher than default, the Pad Status LED will glow green. With each subsequent octave increase, the LED will brighten. When the pitch is an octave lower than default, the Pad Status LED will glow red. With each subsequent octave decrease, the LED will brighten. Pitch can be set over a 10 octave range.

4. Touch each of the remaining seven keys and repeat step 3 to define note values for all eight keys, and for all four outputs.

TIP: Reset any note to its default C (0 V) value by pressing the corresponding encoder.

The following flow diagram illustrates these instructions graphically:

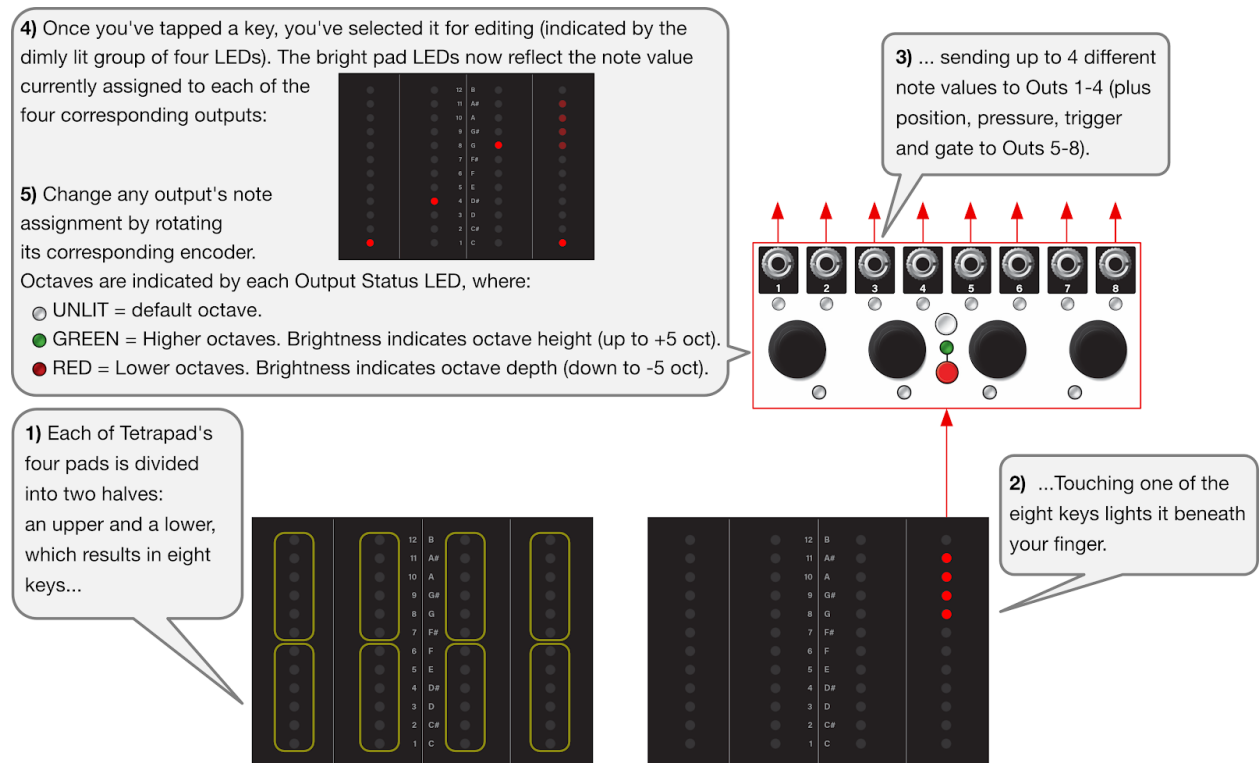

Slew Between Notes

Tetrapad also gives you the ability to slew between notes. To do so, press the red Shift button and continue holding it while turning Encoder 1.

Clockwise turns increase the time it takes to move from one note to another (up to a maximum of about 30 sec for a 10 octave glide). Counterclockwise turns decrease the amount of time (down to “instantaneous”).

Slew times are indicated by a red Pad Status LED above each fader — with an LED glowing increasingly brighter as the slew gets longer.

Slew time is a global setting within Keyboard Mode, meaning the rate of change affects all notes equally.

Playing the Keyboard

1. Tap any of the eight keys to send the custom assigned notes to Outputs 1-4.

That's it. There is no step 2.

But you're free to manually reassign any note at any time using the encoders and the technique discussed earlier, in [Manual Note Assignment](#).

Tuning Mode

Tuning Mode lets you quickly re-configure all four of Tetrapad's note outputs (1 - 4) to send 0V, and its TRIG and GATE outputs (7 - 8) to send high gate signals. This lets you use Tetrapad as a quick tuning reference for any connected oscillators.

To enter Tuning Mode:

1. Hold down the red SHIFT button, then short-press (<1 sec) the white EDIT button.

The center LED turns blue (indicating Tuning Mode). Outputs 1-4 transmit 0V, and Outputs 7-8 transmit high gate signals.

2. When you're done tuning your oscillators, repeat the process (i.e. Hold down the red SHIFT button, then short-press (<1 sec) the white EDIT button.

Tetrapad operation returns to normal.

Mode 5: Chord Mode

Long-press (>1 sec) the white EDIT button to enter Mode selection. Rotate either of the two left encoders to select Mode 5 (as indicated by the position of the brightest Level LED beneath Pad 2). If desired, rotate either of the two right encoders to select one of twelve Mode Presets (indicated by Pad 3), then press Encoder 3 to load your selection. Press the white EDIT button (or either of the two left encoders) to exit Mode selection.

CHORD MODE
(select chords from a library)

1: Set Root Note
(Press while turning to change by octave).
2: Select Chord from Library
3: Rotate Chord
4: Invert Chord

1: Reset Chord Root to C
2: Clear Chord
3: Clear Chord Rotation
4: Clear Inversion

Tetrapad

Note Out 1 Pads 1-4 Note Out 2 Pads 1-4 Note Out 3 Pads 1-4 Note Out 4 Pads 1-4 Position CV Out from any Pad Pressure CV Out from any Pad Trigger Out from any Pad Gate Out from any Pad

Visual indication of output voltage:

- Outs 1-4: Notes
- Out 5: Position (any Pad)
Brightness represents a higher absolute voltage.
- Out 6: Pressure (any Pad)
(brightness = amount)
- Out 7: Trigger (any Pad)
- Out 8: Gate (any Pad)

Visual indication of octave:

- Higher octaves.
(Brightness = oct height, up to 5 octaves above)
- Lower octaves.
(Brightness = oct depth, up to 5 octaves below.)

If you hold SHIFT and turn Encoder 1, this LED displays slow rate rather than octave. The longer the slow time, the brighter the LED:

If you press and hold SHIFT while turning Encoder 1, you can set a slow time between chords.

In Use:

B	●	Tap pad to play a 4-note chord w/notes sent to Outs 1-4.
A#	●	
A	●	
G#	●	
G	●	
F#	●	
F	●	
E	●	
D#	●	
D	●	
C#	●	
C	●	

Ladder LEDs indicate which note is sent to each out (set chords w/encoders).
Each pad plays a different 4-note chord.

All Ladder LEDs light dimly on the most recently touched (and active) pad.

Chord Mode stores a unique 4-note chord for each of the four pads, which you select from a built-in Chord Library. Touching a pad transmits the four notes to the first four outputs, enabling you to play one-finger chords (if you use multiple oscillators). Pads also output both a trigger and a gate signal, and they respond to both position and pressure, giving you

expressive CV control over anything you want (such as a VCA level or filter frequency). Root note changes, inversions and rotations are just an encoder turn away.

Using Chord Mode

In Chord mode, the pads serve two purposes:

- As a performance controller: Touching Pad 1 sends four memorized notes (a chord) to Outputs 1-4; touching Pad 2 sends a different set of notes out the same Outputs; etc.
- As a note/chord display: When you touch Pad 1, the notes it sends to Outs 1-4 are displayed on Pads 1-4. When you touch Pad 2, the notes it sends to Outs 1-4 are then displayed on the four pads.

The notes within each chord are selected from a built-in Chord Library and assigned root, rotation and inversion features as described below:

Chord Selection

Define a chord for each pad by selecting it from the built-in Chord Library, and alter the root note, inversion and chord rotations using the encoders:

1. Touch a pad to select which of the four chords you want to define.

All the ladder LEDs beneath the pad's surface light dimly to indicate that it's the active and editable pad.

2. Rotate Encoder 1 to set the root note of the chord, as it appears on Out 1. If you push Encoder 1 while rotating it, you will change the root's octave.
3. Rotate encoder 2 to scroll through different chords in Tetrapad's library. Selecting different chords changes the note assignments for Outs 2, 3 and 4.

Tetrapad's internal library contains 12 chords, which encoder 2 rotates through continuously, and which are shown in the table on the following page.

4. Rotate encoder 3 to rotate the output assignment of each note.

With each clockwise rotation, the output assignments shift to the right by 1. So if you rotate Encoder 3 one turn CW, the root note moves to Out 2 and all the other output assignments shift to the right by 1, with note 4 now appearing at Out 1.

NOTE: The brightest of the four blue Output Status LEDs indicates which output is currently assigned to the root note. So, as you rotate encoder 3, the bright blue Output Status LED will rotate among the outputs as the chord rotates.

5. Rotate encoder 4 to invert the chord. Clockwise rotation of Encoder 4 inverts the chord upward; Counterclockwise rotation inverts the chord downward.

For example, one CW turn transposes the root note up 1 octave; a second CW turn transposes the second note up 1 octave, and so on. Similarly, one CCW turn transposes the fourth note down 1 octave; etc.

6. Touch each of the remaining three pads and repeat steps 3-6 to define 4-note chords for each of the four pads.

Chord Name	Intervals
Unison	0, 0, 0, 0
Major w/octave	0, 4, 7, 12
Minor w/octave	0, 3, 7, 12
Major 7th	0, 4, 7, 11
Minor 7th	0, 3, 7, 10
Dominant 7th	0, 4, 7, 10
Diminished 7th	0, 3, 6, 9
Half-Diminished 7th	0, 3, 6, 10
Minor Major 7th	0, 3, 7, 11
Augmented Major 7th	0, 4, 8, 11
Augmented 7th	0, 4, 8, 10
Diminished Major 7th	0, 3, 6, 11
Dominant 7th flat 5th	0, 4, 6, 10

Slew Between Chords

Tetrapad gives you the ability to slew between chord changes. To do so, press the red Shift button and continue holding it while turning Encoder 1.

Clockwise turns increase the time it takes to move from one chord to another (up to a maximum of about 30 sec for a 10 octave glide). Counterclockwise turns decrease the amount of time it takes to move from one chord to another (down to “instantaneous”).

Slew times are indicated by a red Pad Status LED above each fader — with an LED glowing increasingly brighter as the slew gets longer.

Note that slew time is a global setting within Chord Mode, meaning the rate of change affects all chords equally.

Performing in Chord Mode

Once you’ve assigned chords to all four pads, you’re ready to perform.

1. Route Tetrapad’s first four outputs to four different oscillators.
2. Press one of the four pads to send a four-note chord to those four oscillators.
3. Press another pad to send another four-note chord, etc.
4. Chord mode also features gate, trigger, position and pressure outputs. These are assigned as follows:

Out 5: Vertical Position of whichever pad you’re currently touching. Brightness of green Output Status LED indicates absolute level.

Out 6: Pressure of whichever pad you’re currently touching. Brightness of red Output Status LED indicates absolute level.

Out 7: Trigger value sent any time you touch any pad. The red Output Status LED turns on, then immediately turns off when a pad is touched — indicating a trigger output.

Out 8: Gate signal sent any time you touch any pad. The red Output Status LED turns on and stays on as long as a pad is touched — indicating a gate output.

5. Route these last four outputs to envelopes or control voltage inputs on other modules to enable more expressive and organic performances.

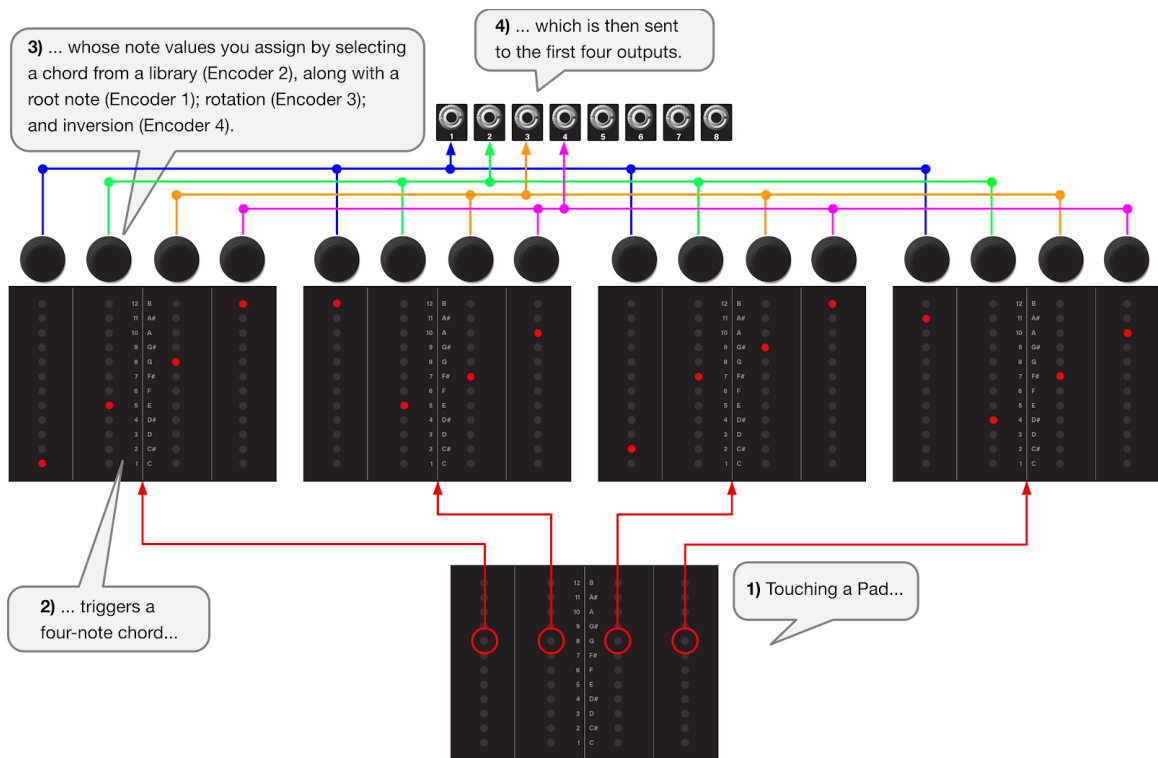

Tuning Mode

Tuning Mode lets you quickly re-configure all four of Tetrapad's note outputs (1 - 4) to send 0V, and its TRIG and GATE outputs (7 - 8) to send high gate signals. This lets you use Tetrapad as a quick tuning reference for any connected oscillators.

To enter Tuning Mode:

1. Hold down the red SHIFT button, then short-press (<1 sec) the white EDIT button.
The center LED turns blue (indicating Tuning Mode). Outputs 1-4 transmit 0V, and Outputs 7-8 transmit high gate signals.
2. When you're done tuning your oscillators, repeat the process (i.e. Hold down the red SHIFT button, then short-press (<1 sec) the white EDIT button).

Tetrapad operation returns to normal.

Mode 6: Custom Chord Mode

Long-press (>1 sec) the white EDIT button to enter Mode selection. Rotate either of the two left encoders to select Mode 6 (as indicated by the position of the brightest Level LED beneath Pad 2). If desired, rotate either of the two right encoders to select one of twelve Mode Presets (indicated by Pad 3), then press Encoder 3 to load your selection. Press the white EDIT button (or either of the two left encoders) to exit Mode selection.

For each Pad:

- 1: Sets chord's root note (appears on Out 1)
Transposes the entire chord.
- 2: Sets 2nd note in chord (appears on Out 2)
- 3: Sets 3rd note in chord (appears on Out 3)
- 4: Sets 4th note in chord (appears on Out 4)

↓

- 1: Resets chord to the root of C.
- 2-4: Resets Out to C (0V)

Press & turn 1 to xpose chord by octave.
Press & turn 2-4 to xpose individual note by octave.

Tetrapad

CUSTOM CHORD MODE
(note-by-note entry of chords)

Visual indication of octave:

- Higher octaves. (Brightness = oct height, up to 5 octaves above)
- Lower octaves. (Brightness = oct depth, up to 5 octaves below.)

If you hold SHIFT and turn Encoder 1, this LED displays slew rate rather than octave. The longer the slew time, the brighter the LED:

○ - ● - ● - ●

Visual indication of output voltage:

- Outs 1-4: Notes
- Out 5: Position (any Pad)
Brightness represents a higher absolute voltage.
- Out 6: Pressure (any Pad)
(brightness = amount)
- Out 7: Trigger (any Pad)
- Out 8: Gate (any Pad)

If you press and hold SHIFT while turning Encoder 1, you can set a slew time between chords.

In Use:

- Tap pad to play a 4-note chord w/notes sent to Outs 1-4.
- Ladder LEDs indicate which note is sent to each output. (set w/encoder)
- Each pad plays a different 4-note chord.

All Ladder LEDs light dimly on the most recently touched (and active) pad.

Page 54

Custom Chord Mode stores a unique 4-note chord for each of the four pads. Touching a pad transmits the four notes to the first four outputs, enabling you to play one-finger chords (if you use multiple oscillators). Pads also output both a trigger and a gate signal, and they respond to both position and pressure, giving you expressive CV control over anything you want (such as a VCA level or filter frequency). Unlike standard Chord Mode, Custom Chord Mode lets you define your own chord patterns, allowing for harmonic structures beyond those included in Mode 5's Chord Library.

Using Custom Chord Mode

In Custom Chord mode, the pads serve two purposes:

- As a performance controller: Touching Pad 1 sends four memorized notes (a chord) to outputs 1-4; touching Pad 2 sends a different set of notes out the same outputs; etc.
- As a note/chord display: When you touch Pad 1, the notes it sends to Outs 1-4 are displayed on Pads 1-4. When you touch Pad 2, the notes it sends to Outs 1-4 are then displayed on the four pads.

The notes within each chord are edited directly by turning the four encoders, as described below.

Chord Entry

1. Touch one of the four pads to select it for chord editing.

All the ladder LEDs beneath the pad's surface light dimly to indicate that it's the active and editable pad.

2. Rotate Encoder 1 to set the chord's root note, which is sent to Out 1. Rotate encoders 2-4 to set the interval values, which Tetrapad sends to Outputs 2-4.

Beneath the surface of each pad is a brightly lit LED, indicating the note value assigned to the corresponding Output number (as seen with the Level Label in the center of the four pads). That is, the bright LED beneath Pad 1 shows the note sent to Out 1; the bright LED beneath Pad 2 shows the note sent to Out 2; etc.

3. Press & turn an encoder to increment or decrement its note assignment by octave.

The Pad Status LED glows an increasingly brighter green for each octave higher than default. It glows increasingly brighter red for each octave lower than the default. Notes can be set over a 10 octave range.

4. To transpose the chord, simply rotate Encoder 1 to change the root note, shifting all four Outs up/down accordingly.

Similarly, push-turning Encoder 1 transposes the entire chord up/down by octave.

5. Press an encoder if you want to reset its output to C (0V). Pressing Encoder 1 transposes the entire chord to the root of C.
6. Touch each of the remaining three pads and repeat steps 2-5 to define 4-note chords for each of the four pads.

Slew Between Chords

Tetrapad gives you the ability to slew between chord changes. To do so, press the red Shift button and continue holding it while turning Encoder 1.

Clockwise turns increase the time it takes to move from one chord to another (up to a maximum of about 30 sec for a 10 octave glide). Counterclockwise turns decrease the amount of time it takes to move from one chord to another (down to “instantaneous”).

Slew times are indicated by a red Pad Status LED above each fader — with an LED glowing increasingly brighter as the slew gets longer.

Note that slew time is a global setting within Chord Mode, meaning the rate of change affects all chords equally.

Performing in Custom Chord Mode

Once you've assigned chords to all four pads, you're ready to perform.

1. Route Tetrapad's first four outputs to four different oscillators.
2. Press one of the four pads to send a four-note chord to those four oscillators.
3. Press another pad to send another four-note chord, etc.
4. Chord mode also features gate, trigger, position and pressure outputs. These are assigned as follows:

Out 5: Vertical Position of whichever pad you're currently touching. Brightness of green Output Status LED indicates absolute level.

Out 6: Pressure of whichever pad you're currently touching. Brightness of red Output Status LED indicates absolute level.

Out 7: Trigger value sent any time you touch any pad. The red Output Status LED turns on, then immediately turns off when a pad is touched — indicating a trigger output.

Out 8: Gate signal sent any time you touch any pad. The red Output Status LED turns on and stays on as long as a pad is touched — indicating a gate output.

- Route these last four outputs to envelopes or control voltage inputs on other modules to enable more expressive and organic performances.

By way of example, look at the following illustration. We see that touching Pad 1 sends C-E-G-B to Outputs 1-4; touching Pad 2 sends a B-E-F#-A to Outputs 1-4; Pad 3 sends C#-F#-G#-B to Outs 1-4; and Pad 4 sends A#-D#-F#-A to Outs 1-4:

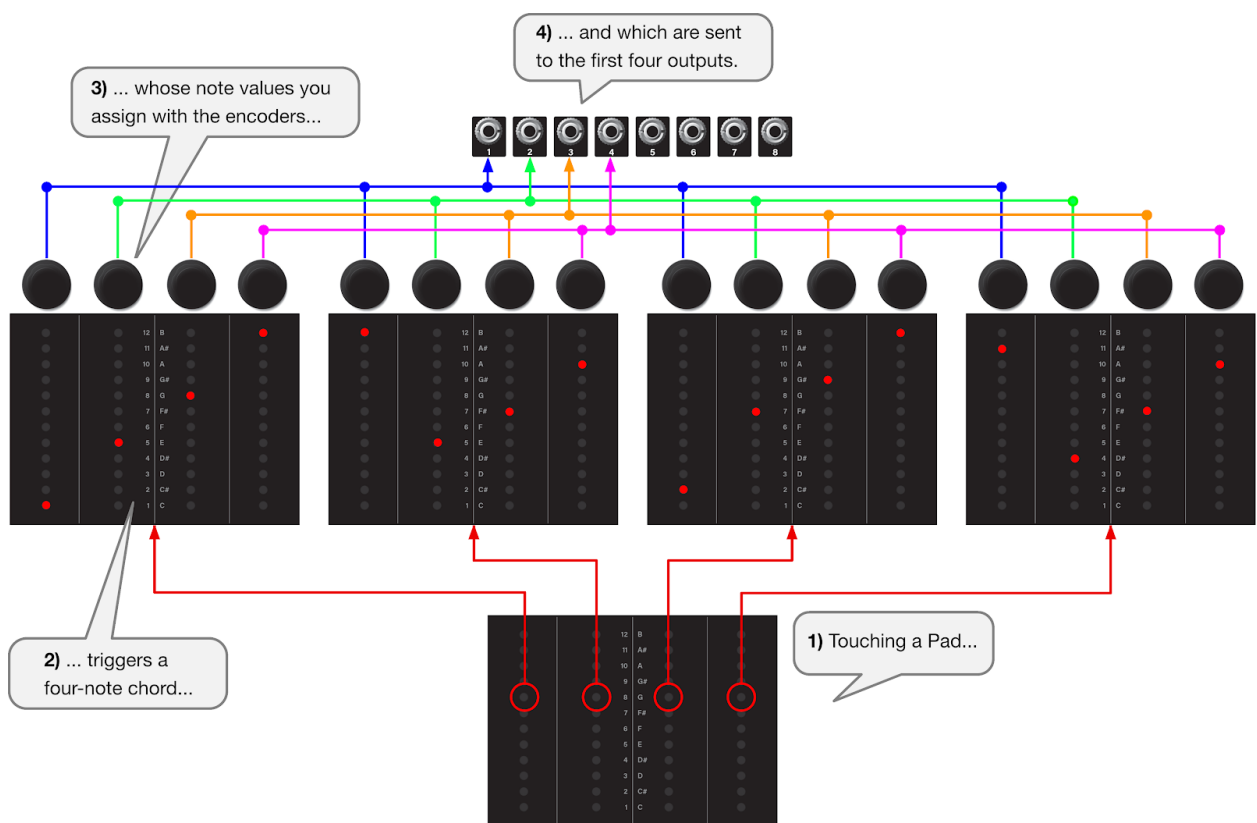

Tuning Mode

Tuning Mode lets you quickly re-configure all four of Tetrapad's note outputs (1 - 4) to send 0V, and its TRIG and GATE outputs (7 - 8) to send high gate signals. This lets you use Tetrapad as a quick tuning reference for any connected oscillators.

To enter Tuning Mode:

1. Hold down the red SHIFT button, then short-press (<1 sec) the white EDIT button.
The center LED turns blue (indicating Tuning Mode). Outputs 1-4 transmit 0V, and Outputs 7-8 transmit high gate signals.
2. When you're done tuning your oscillators, repeat the process (i.e. Hold down the red SHIFT button, then short-press (<1 sec) the white EDIT button.
Tetrapad operation returns to normal.

Mode 12: Global Configuration

Long-press (>1 sec) the white EDIT button to enter Mode selection. Rotate either of the two left encoders to select Mode 12 (as indicated by the position of the brightest Level LED beneath Pad 2). Press the white EDIT button (or either of the two left encoders) to exit Mode selection.

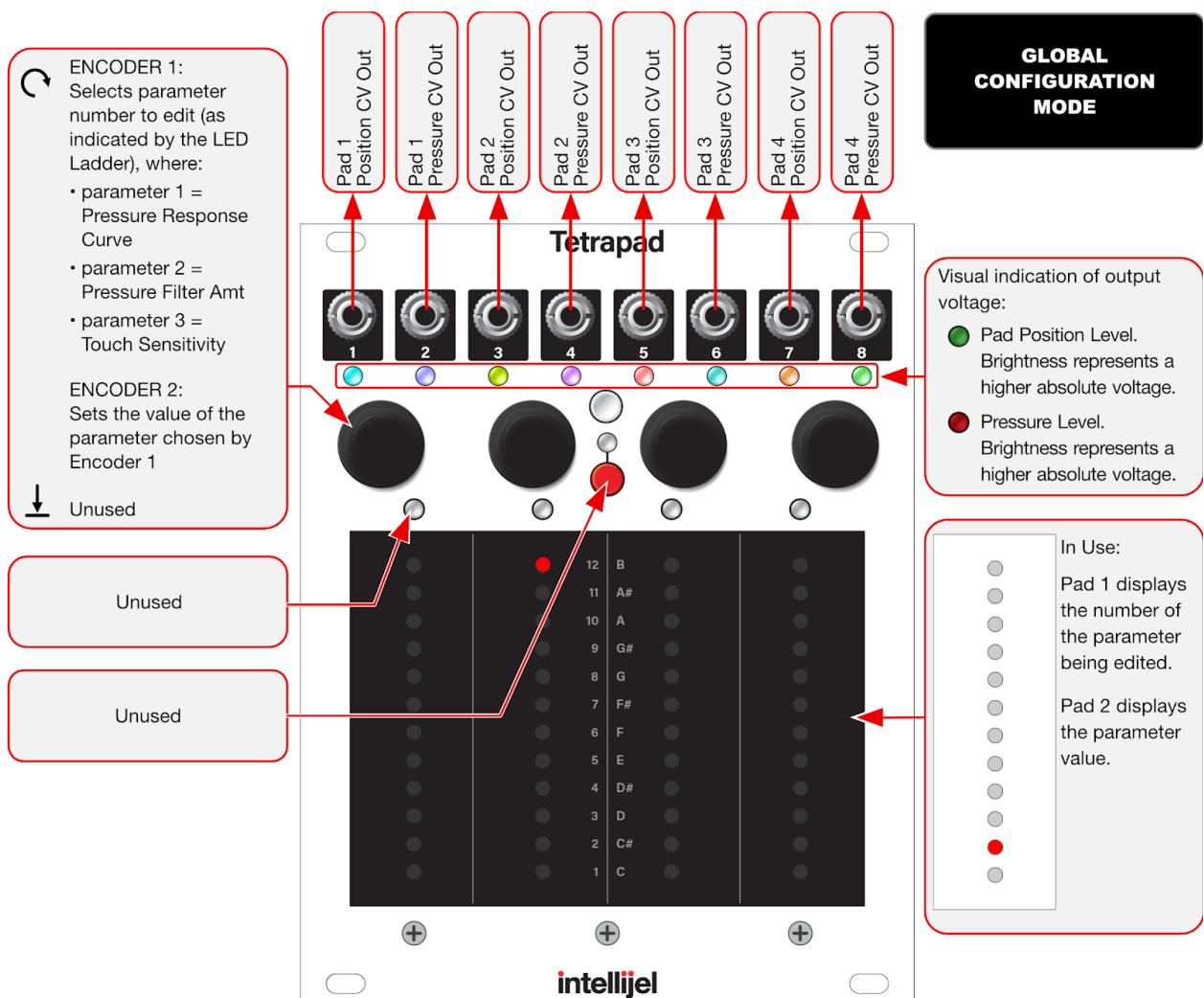

In Global Configuration Mode, each pad has a corresponding pair of active outputs, so you can test the effect of your settings while still in Configuration Mode. Each pad's position CV appears at its odd numbered out, and its pressure CV appears at the even.

Using Global Configuration Mode

To adjust the pressure response curve:

1. Rotate Encoder 1 until the first LED is lit beneath the surface of Pad 1.

The first LED indicates that you're editing Parameter #1, which is the Pressure Response Curve parameter.

2. Rotate Encoder 2 to select the desired pressure response curve.

There are four options, numbered 1-4 (as indicated by the LEDs beneath the pad's surface). These are: 1: Square (factory default); 2: Linear; 3: Exponential; and 4: Logarithmic.

These are indicated graphically in the following illustration:

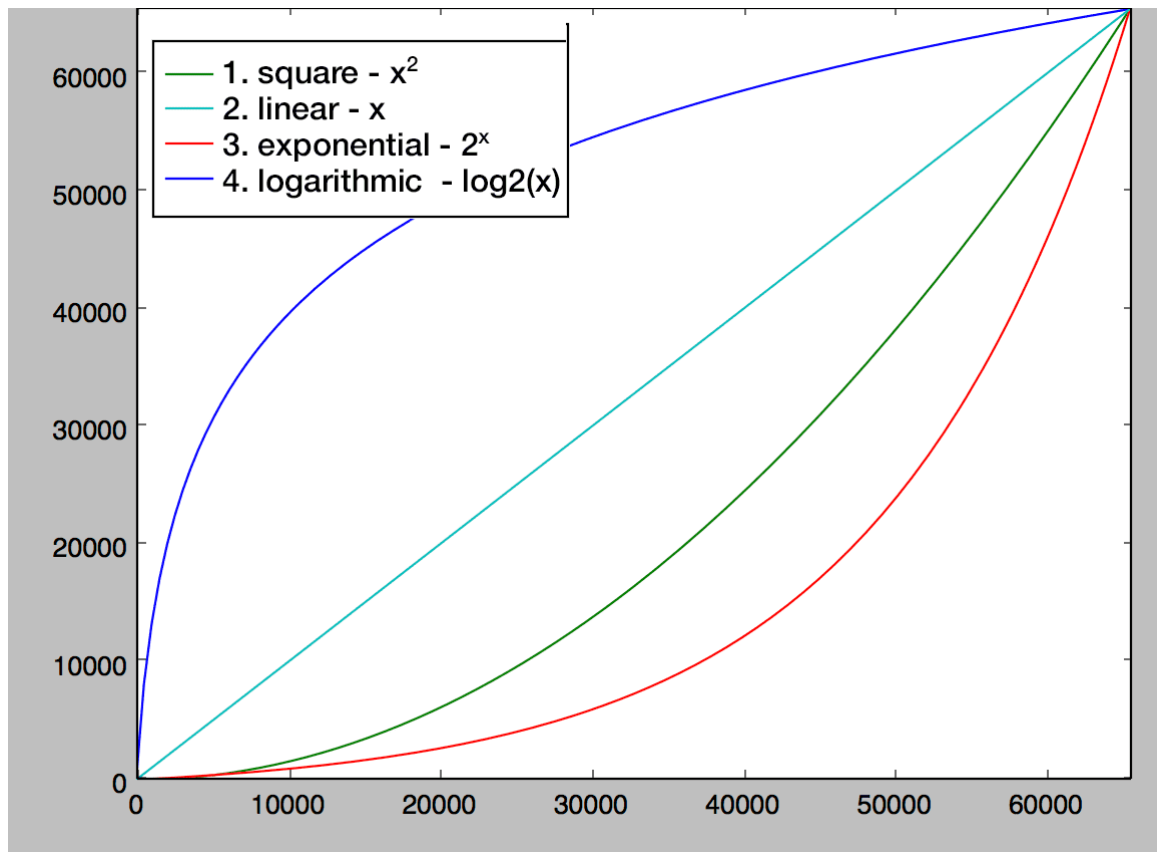

To adjust the pressure filter:

1. Rotate Encoder 1 until the second LED is lit beneath the surface of Pad 1.

The second LED indicates that you're editing Parameter #2, which is the Pressure Filter parameter.

2. Rotate Encoder 2 to select the desired filter.

There are 12 filtration levels, numbered 1-12 (as indicated by the LEDs beneath the pad's surface). Higher numbers are more sensitive to pressure variation than lower numbers. Tetrapad ships with a default level of 7.

To adjust the touch sensitivity:

1. Rotate Encoder 1 until the third LED is lit beneath the surface of Pad 1.

The third LED indicates that you're editing Parameter #3, which is the Touch Sensitivity parameter.

2. Rotate Encoder 2 to select the desired touch sensitivity.

There are 12 sensitivity levels, numbered 1-12 (as indicated by the LEDs beneath the pad's surface). Higher numbers are more sensitive to the touch of your finger but slightly less sensitive to its position, while lower numbers are less sensitive to touch, but more sensitive to position. Touch sensitivity has the most obvious effect in highly-reactive modes, like Mode 1: Faders Mode, where the way in which you touch a fader has the most effect on the CV values it transmits. Tetrapad ships with a default value level of 7.

Output Voltage Calibration

Mode 12 contains a hidden Output Voltage Calibration mode, which enables you to precisely calibrate each of Tetrapad's 8 outputs. Tetrapad is calibrated at the factory prior to shipment, so it's very unlikely you'll ever need to perform any custom calibration. But if you do, these instructions (along with an external voltage meter) are all you need to calibrate it.

To enter Output Voltage Calibration Mode:

1. Make sure Tetrapad is in Mode 12: Global Configuration Mode.

To do so: Long-press (>1 sec) the white EDIT button to enter Mode selection. Rotate either of the two left encoders to select Mode 12 (as indicated by the position of the brightest Level LED beneath Pad 2). Press the white EDIT button (or either of the two left encoders) to exit Mode selection.

Tetrapad is now in Mode 12: Global Configuration Mode, and an LED lights beneath pads 1 and 2 on Tetrapad.

2. Short-press the white EDIT button again.

A single red LED lights beneath one of the 8 output jacks.

Tetrapad is now in its Output Voltage Calibration Mode, as shown in the illustration on the following page.

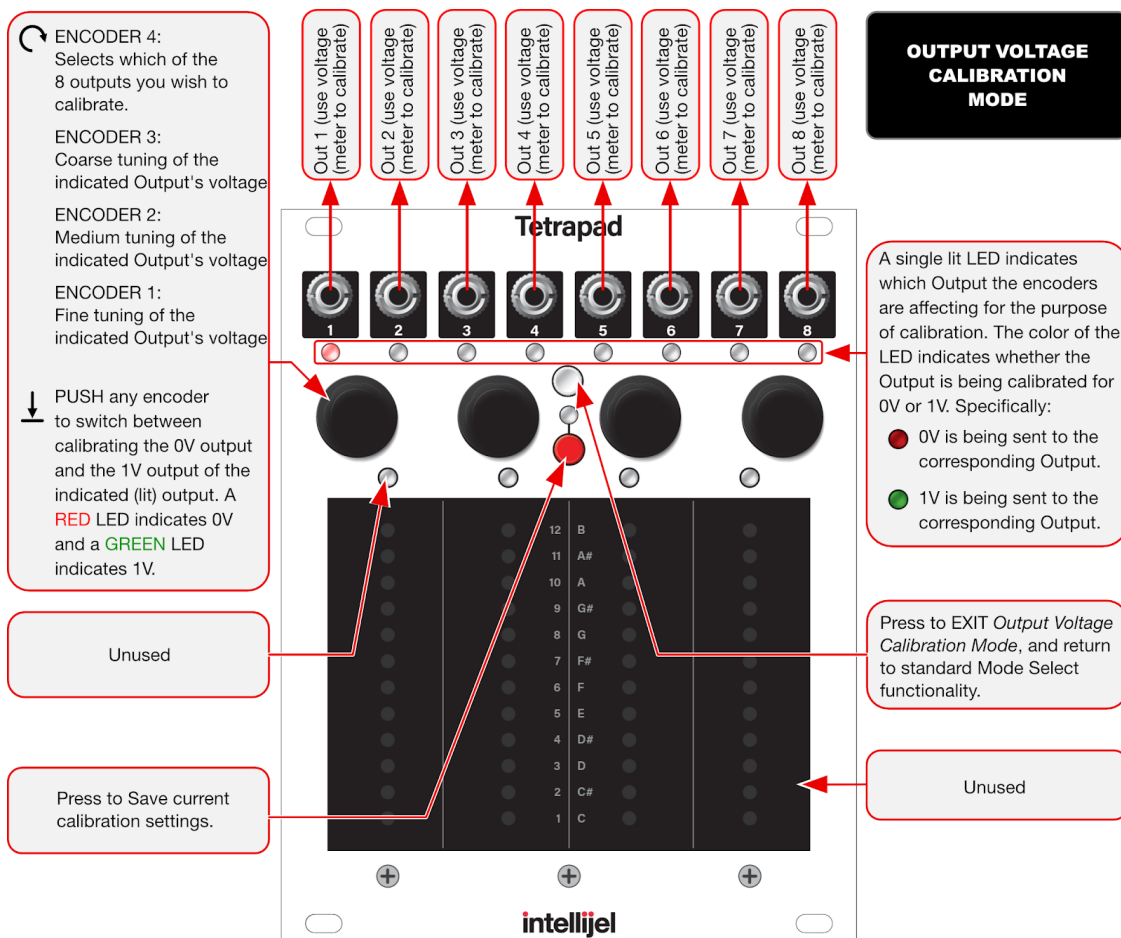

To Calibrate an Output:

1. Rotate the right-most encoder (Encoder 4) to select which of the 8 output voltages you wish to calibrate. The single LED moves beneath the selected output jack to indicate which output is to be calibrated.

2. Plug a high resolution voltage meter into the Output jack whose LED is lit.

You will calibrate an output to two different voltages: 0V (as indicated by a red Output Status LED) and 1V (as indicated by a green Output Status LED). Let's begin with the 0V calibration:

3. If the Output Status LED is currently green, push any of the four encoders to change its color to red. A red Output Status LED indicates 0V.
4. Rotate the three left encoders to set the output voltage as close to 0V as possible.

The third encoder from the left (Encoder 3) is the coarse setting. The first encoder on the left (Encoder 1) is the fine setting. Between them is Encoder 2, which provides a voltage adjustment between fine and coarse.

5. Push any of the encoders to change the Output Status LED to green, indicating that 1V is now appearing at the corresponding output.
6. Rotate the three left-most encoders to set the output voltage as close to 1V as possible. Again, these three encoders are arranged with the finest control on the left.
7. To calibrate additional outputs, repeat steps 1-6.
8. Press the red SHIFT button to save the calibration.

To exit Output Voltage Calibration Mode:

1. Press the white EDIT button, and Tetrapad will exit Output Voltage Calibration Mode, returning it to standard Mode Select view.

Long-press (>1 sec) the white EDIT button to enter Mode Selection. To enter the hidden Output Voltage Calibration mode, long-press the EDIT button a second time until a single red LED lights beneath one of the 8 output jacks. To exit Output Voltage Calibration mode, press the white EDIT button (returning Tetrapad to standard Mode Select view).

Firmware Version Display

When you first power up Tetrapad, all its LEDs blink rhythmically for a few seconds. After the light show completes and immediately before the module is ready to use, it displays (for about 1 second) the current firmware version using the Level LEDs embedded beneath each of the four pads. The display methodology used by versions 1 and 2 is different than the method used by version 3. Both are shown below:

Version 3 Firmware Display Method

For Tetrapad version 3, the four pads represent version X.Y.Y.Y as shown to the right.:

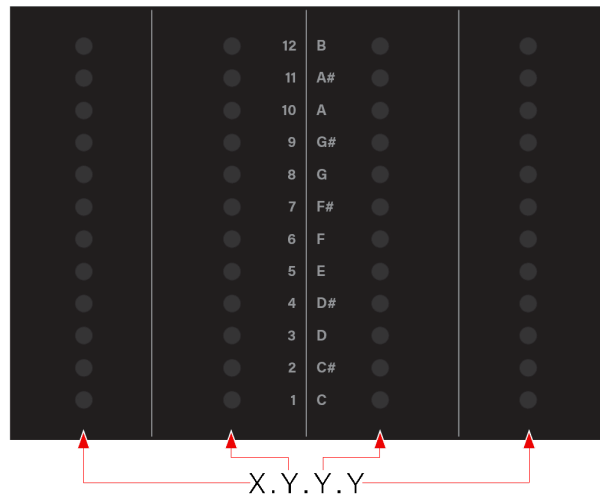

For example, version 3.1.2.0 would appear as shown here:

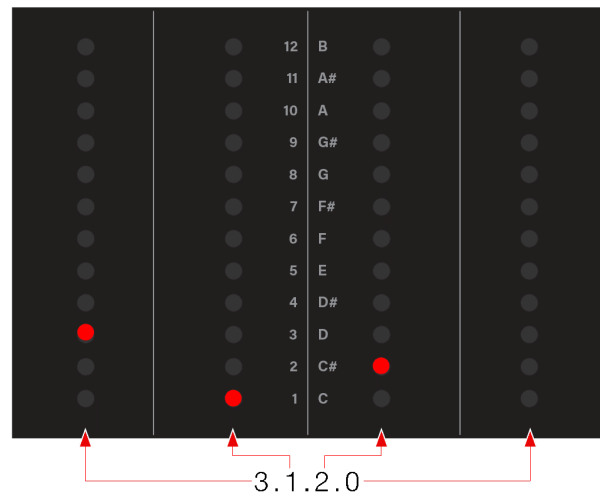

Version 1 & 2 Firmware Display Method

For Tetrapad versions 1 and 2, the four pads represent version xx.yy as follows:

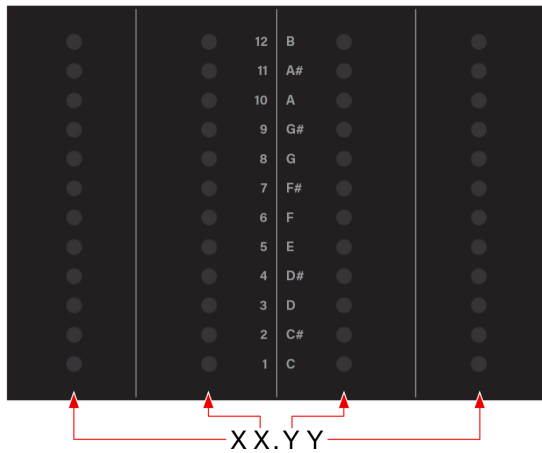

For example, version 1.10 would appear as shown on the left, and version 2.0 firmware would appear as shown on the right:

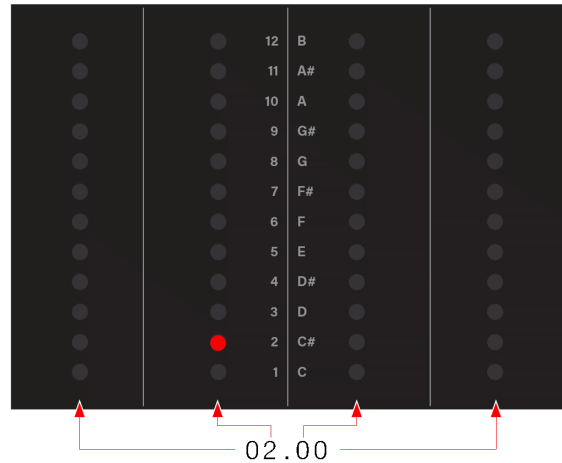
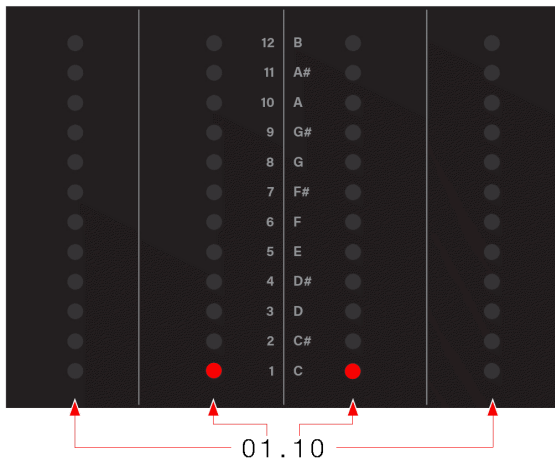

Firmware Change Log

3.0.0.3 (March 27, 2020)

Note: This fix only affects standalone Tetrapad operation. No difference will be noticed when connected to a Tête.

- BUGFIX: Latched bi-polar pads Combo Mode loading at -5V.

3.0.0.2 (March 26, 2020)

Note: These changes only affect standalone Tetrapad operation. No difference will be noticed when connected to a Tête.

- FEATURE: Pad Status LEDs light up green when you save a preset.
- FEATURE: Doubled the slowest slew time in Combo Mode.
- BUGFIX: Combo Mode presets were not loading some parameters.
- BUGFIX: Fixed Encoder response glitches introduced in 3.0.0.1.

3.0.0.1 (March 02, 2020)

- CHANGE: Coarse/Fine tuning now handled with Encoder Acceleration. Turn slowly for fine increments, and turn faster to increment more coarsely. (No need to Push-Turn the encoder for fine increments).

3.0.0.0 (November, 2019)

- FEATURE: Added support for Tête.

When connected to the Tête, please refer to the dedicated Tête + Tetrapad manual (rather than this manual) as Tetrapad functionality differs substantially when used with Tête.

- FEATURE: Tuning Mode (When Tetrapad is used standalone, without Tête).

Tuning Mode operates in the Chord/Keyboard modes, and enables Tetrapad to send out a 0V, "on" gate signal to use as an oscillator tuning aid. Hold down red SHIFT button, then short-press (<1 sec) white EDIT button. Center LED will turn BLUE, gates will go high, and pitch will go to C0. Repeat the process to exit Tuning Mode.

- BUGFIX: Easier to touch the extreme ends of the pads/voltage range

2.00 (Oct 25, 2018)

- FEATURE: [Combo Mode](#) introduced.
- FEATURE: [Mode Presets](#) introduced. Each mode can have up to twelve different user-programmable preset configurations.

1.10 (June 15, 2018)

- FEATURE: Voltage mode slew rates dependent on pressure.
- FEATURE: Increased maximum slew times.
- BUGFIX: Fixed lydian scale notes.
- BUGFIX: Fixed voltage range for voltages mode.

1.00 (November, 2017)

- Initial Release

Technical Specifications

Width	20 hp
Maximum Depth	19 mm
Current Draw	130 mA @ +12V 15 mA @ -12V