

## User Manual



# EUROPOWER PMP1680S/PMP980S/PMP960M

1600/900-Watt 10/6-Channel Powered Mixer with  
Dual Multi-FX Processor and FBQ Feedback Detection System

# Table of Contents

<b>Thank you .....</b>	<b>2</b>
<b>Important Safety Instructions .....</b>	<b>3</b>
<b>Legal Disclaimer .....</b>	<b>3</b>
<b>Limited warranty .....</b>	<b>3</b>
<b>1. Before you get Started .....</b>	<b>4</b>
1.1 Shipment.....	4
1.2 Initial operation .....	4
1.3 Online registration .....	4
1.4 The manual .....	4
<b>2. Control Elements .....</b>	<b>6</b>
2.1 Mono and stereo channels.....	6
2.2 Effects section .....	6
2.3 Main and monitor section.....	6
2.4 Rear panel .....	7
<b>3. Digital Effects Processor .....</b>	<b>8</b>
<b>4. Installation .....</b>	<b>8</b>
4.1 Mains connection .....	8
4.2 Audio connections.....	8
4.3 Loudspeaker connection.....	9
<b>5. Wiring Examples .....</b>	<b>10</b>
<b>6. Specifications.....</b>	<b>12</b>

## Thank you

Thank you for choosing one of the PMP series powered mixers from BEHRINGER. These mixers pack impressive features such as digital effects, graphic EQs, FBQ feedback destroyer and unique voice cancelling function – all in a lightweight, portable package. You now have a versatile combination of inputs, routing options, effects and power amp operations for your rehearsal space, small venue or portable PA needs. But why bother with manuals? We know you want to get started right away, but please read this manual carefully and keep it handy for ongoing reference. These instructions show you all the inside features, tricks, and tips you need to build the best possible sound with your new PMP powered mixer.

After all, it's all about your sound.

**EN Important Safety Instructions**

Terminals marked with this symbol carry electrical current of sufficient magnitude to constitute risk of electric shock.

Use only high-quality professional speaker cables with ¼" TS or twist-locking plugs pre-installed. All other installation or modification should be performed only by qualified personnel.



This symbol, wherever it appears, alerts you to the presence of uninsulated dangerous voltage inside the enclosure - voltage that may be sufficient to constitute a risk of shock.



This symbol, wherever it appears, alerts you to important operating and maintenance instructions in the accompanying literature. Please read the manual.

**Caution**

To reduce the risk of electric shock, do not remove the top cover (or the rear section). No user serviceable parts inside. Refer servicing to qualified personnel.

**Caution**

To reduce the risk of fire or electric shock, do not expose this appliance to rain and moisture. The apparatus shall not be exposed to dripping or splashing liquids and no objects filled with liquids, such as vases, shall be placed on the apparatus.

**Caution**

These service instructions are for use by qualified service personnel only. To reduce the risk of electric shock do not perform any servicing other than that contained in the operation instructions. Repairs have to be performed by qualified service personnel.

1. Read these instructions.
2. Keep these instructions.
3. Heed all warnings.
4. Follow all instructions.
5. Do not use this apparatus near water.
6. Clean only with dry cloth.
7. Do not block any ventilation openings. Install in accordance with the manufacturer's instructions.
8. Do not install near any heat sources such as radiators, heat registers, stoves, or other apparatus (including amplifiers) that produce heat.

9. Do not defeat the safety purpose of the polarized or grounding-type plug. A polarized plug has two blades with one wider than the other. A grounding-type plug has two blades and a third grounding prong. The wide blade or the third prong are provided for your safety. If the provided plug does not fit into your outlet, consult an electrician for replacement of the obsolete outlet.

10. Protect the power cord from being walked on or pinched particularly at plugs, convenience receptacles, and the point where they exit from the apparatus.

11. Use only attachments/accessories specified by the manufacturer.



12. Use only with the cart, stand, tripod, bracket, or table specified by the manufacturer, or sold with the apparatus. When a cart is used, use caution when moving the cart/apparatus combination to avoid

injury from tip-over.

13. Unplug this apparatus during lightning storms or when unused for long periods of time.

14. Refer all servicing to qualified service personnel. Servicing is required when the apparatus has been damaged in any way, such as power supply cord or plug is damaged, liquid has been spilled or objects have fallen into the apparatus, the apparatus has been exposed to rain or moisture, does not operate normally, or has been dropped.

15. The apparatus shall be connected to a MAINS socket outlet with a protective earthing connection.

16. Where the MAINS plug or an appliance coupler is used as the disconnect device, the disconnect device shall remain readily operable.



TO BIND MUSIC GROUP BY ANY EXPRESS OR IMPLIED UNDERTAKING OR REPRESENTATION. THIS MANUAL IS COPYRIGHTED. NO PART OF THIS MANUAL MAY BE REPRODUCED OR TRANSMITTED IN ANY FORM OR BY ANY MEANS, ELECTRONIC OR MECHANICAL, INCLUDING PHOTOCOPYING AND RECORDING OF ANY KIND, FOR ANY PURPOSE, WITHOUT THE EXPRESS WRITTEN PERMISSION OF MUSIC GROUP IP LTD.

ALL RIGHTS RESERVED.

© 2013 MUSIC Group IP Ltd.

Trident Chambers, Wickhams Cay, P.O. Box 146, Road Town, Tortola, British Virgin Islands

**LIMITED WARRANTY**

For the applicable warranty terms and conditions and additional information regarding MUSIC Group's Limited Warranty, please see complete details online at [www.music-group.com/warranty](http://www.music-group.com/warranty).

**LEGAL DISCLAIMER**

TECHNICAL SPECIFICATIONS AND APPEARANCES ARE SUBJECT TO CHANGE WITHOUT NOTICE AND ACCURACY IS NOT GUARANTEED. BEHRINGER, KLARK TEKNIK, MIDAS, BUGERA, AND TURBOSOUND ARE PART OF THE MUSIC GROUP (MUSIC-GROUP.COM). ALL TRADEMARKS ARE THE PROPERTY OF THEIR RESPECTIVE OWNERS. MUSIC GROUP ACCEPTS NO LIABILITY FOR ANY LOSS WHICH MAY BE SUFFERED BY ANY PERSON WHO RELIES EITHER WHOLLY OR IN PART UPON ANY DESCRIPTION, PHOTOGRAPH OR STATEMENT CONTAINED HEREIN. COLORS AND SPECIFICATIONS MAY VARY FROM ACTUAL PRODUCT. MUSIC GROUP PRODUCTS ARE SOLD THROUGH AUTHORIZED FULLFILLERS AND RESELLERS ONLY. FULLFILLERS AND RESELLERS ARE NOT AGENTS OF MUSIC GROUP AND HAVE ABSOLUTELY NO AUTHORITY

# 1. Before you get Started

## 1.1 Shipment

Your PMP mixer was carefully packed at the factory and the packaging is designed to protect the unit from rough handling. Nevertheless, we recommend that you carefully examine the packaging and its contents for any signs of physical damage which may have occurred during transit.

- ◆ **If the unit is damaged, please do NOT return it to BEHRINGER, but notify your dealer and the shipping company immediately. Otherwise, claims for damage or replacement may not be granted.**
- ◆ **We recommend that you use a flight case, so as to give your power mixer optimum protection during use or transport.**
- ◆ **Always use the original packing carton to prevent damage during storage or transport.**
- ◆ **Make sure that children cannot play unsupervised with the device or its packaging.**
- ◆ **Please ensure proper disposal of all packing materials.**

## 1.2 Initial operation

Be sure that there is enough air space around the unit for cooling and, to avoid overheating, please do not place the EUROPOWER near radiators, etc.

- ◆ **Blown fuses must be replaced by fuses of the same type and rating! Please refer to the "Specifications" for details.**

The mains connection is made using the enclosed power cord and a standard IEC receptacle. It meets all of the international safety certification requirements.

- ◆ **Please make sure that all units have proper ground connection. For your own safety, never remove or disable the ground conductor from the unit or on the AC power cord.**
- ◆ **Important notes concerning installation: The sound quality may diminish within the range of powerful broadcasting stations and high-frequency sources. Increase the distance between the transmitter and the device and use shielded cables for all connections.**

## 1.3 Online registration

Please register your new BEHRINGER equipment right after your purchase by visiting <http://behringer.com> and read the terms and conditions of our warranty carefully.

Should your BEHRINGER product malfunction, it is our intention to have it repaired as quickly as possible. To arrange for warranty service, please contact the BEHRINGER retailer from whom the equipment was purchased. Should your BEHRINGER dealer not be located in your vicinity, you may directly contact one of our subsidiaries. Corresponding contact information is included in the original equipment packaging (Global Contact Information/European Contact Information). Should your country not be listed, please contact the distributor nearest you. A list of distributors can be found in the support area of our website (<http://behringer.com>).

Registering your purchase and equipment with us helps us process your repair claims more quickly and efficiently.

Thank you for your cooperation!

## 1.4 The manual

This manual is designed to give you both an overview of all control elements and to provide detail about how to use them. To provide you with a clear structure, we have grouped the control elements according to their function. They can easily be found on the enclosed numbered illustrations. If you need more detailed information on specific topics, please visit our web site [behringer.com](http://behringer.com). The product-related information pages and the Ultranet-based glossary explain the relevant audio engineering terminology in full detail.

# Front Panel

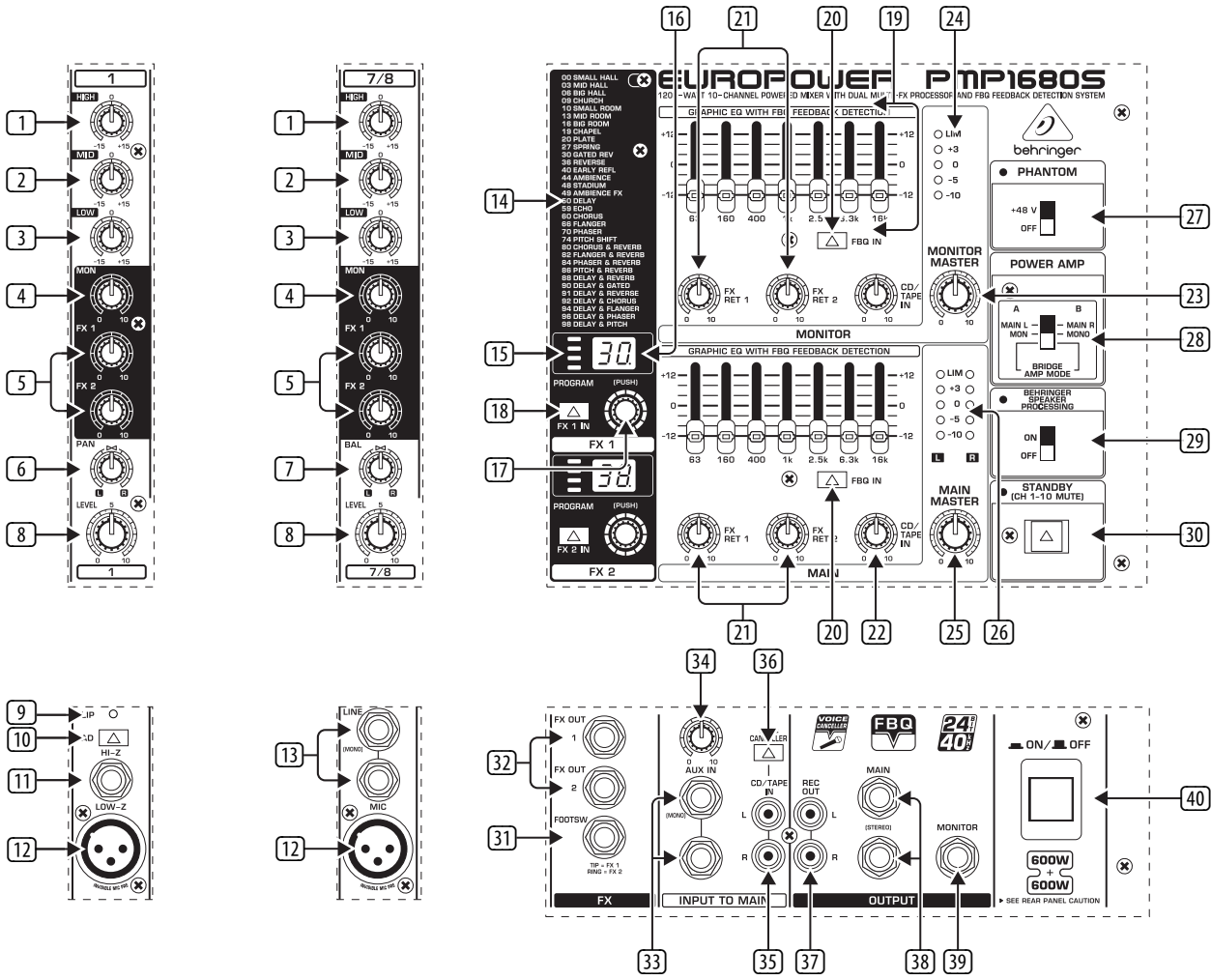

# Rear Panel

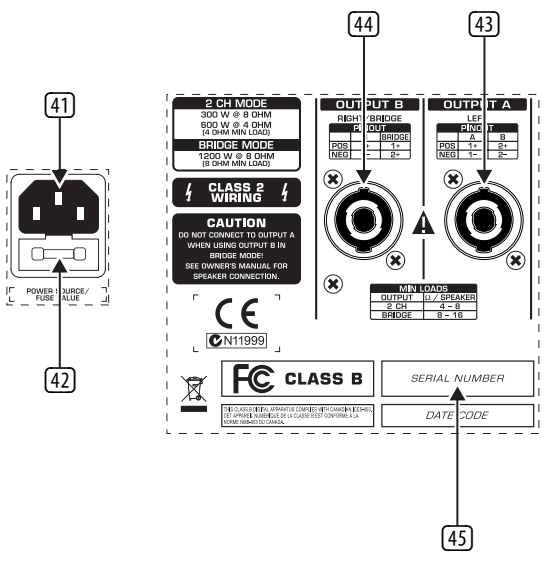

## 2. Control Elements

A detailed description of all functions of your power mixer can be found in the following chapters. Please also refer to the enclosed sheet with the numbered illustrations to get an overview of the control layout.

### 2.1 Mono and stereo channels

- 1 The **HIGH** control in the EQ section governs the high-frequency range of the respective channel.
  - 2 Use the **MID** control to boost or cut the mid-range frequencies.
  - 3 The **LOW** control allows you to boost/cut the low-frequency range.
  - 4 With the **MON** control you can adjust the volume of each channel in the monitor mix.
  - 5 The **FX** control determines the signal level sent from each channel to the built-in effects processor; this signal is also present at the FX OUT jack (see 32). The PMP980S/PMP1680S has two FX controls (FX 1 and FX 2), so that you can use two effects simultaneously. Accordingly, it also provides two effect Aux paths (see 32).
- ♦ Please note that the effects processor signal will be inaudible when the FX RETURN control 21 is set fully counter-clockwise.
- 6 For the mono input channels, the PMP980S/PMP1680S has a **PAN(ORAMA)** control which determines the position of the channel signal in the stereo main mix. The PMP960M has no PAN on the input channels, because it is a dual-mono power mixer.
  - 7 The **BAL(ANCE)** control for the stereo channels of the PMP980S/PMP1680S corresponds to the PAN control for the mono channels. It determines the relative volume of the left and right input signals before they are routed to the stereo main output. The PMP960M has no stereo channels and hence no BAL control, because it is a dual-mono power mixer.
  - 8 The **LEVEL** control adjusts the channel signal level in the main mix.

#### 2.1.1 Input section

- 9 The **CLIP LED** is very useful to control the input gain. It should never be constantly illuminated (only with signal peaks).
  - 10 The **PAD** switch reduces the input sensitivity of the channel by approx. 30 dB, to connect for example line-level signals.
  - 11 The balanced **HI-Z** input (1/4" TRS) can be used for line-level signal sources, e.g. keyboards, electric guitars and basses.
  - 12 Each channel has a balanced **LOW-Z** microphone input with XLR connectors, which also supply the +48 V phantom power for condenser microphones (see 27).
  - 13 Unbalanced stereo line inputs with 1/4" connectors for stereo channels 7 to 10 of the PMP980S/PMP1680S. They can be used for connecting keyboards with stereo outputs or stereo drum machines.
- ♦ Please remember to use either the microphone or the line input of a channel at a time, but never both at the same time!

### 2.2 Effects section

- 14 List of all multi-effects presets.
- 15 LED level meter of the effects processor. Since the PMP980S/PMP1680S allows you to select two effects simultaneously, it also has two level meters (DUAL FX). Be sure that the clip LED illuminates for signal peaks only. If it is illuminated all the time, it is a sign that the effects processor is overloading and hence producing unpleasant distortion.

- 16 The Effect display (PMP980S/PMP1680S: two displays) shows the currently selected preset.
- 17 Turn the **PROGRAM** control (PMP980S/PMP1680S: one control each for FX 1 and FX 2) to select an effects preset (preset number starts flashing). Push the control briefly to confirm your selection.
- 18 Press the **FX IN** button (PMP980S/PMP1680S: FX 1 IN and FX 2 IN) to activate the effects processor.

### 2.3 Main and monitor section

- 19 Your power mixer is equipped with two graphic 7-band equalizers. The upper one processes the monitor signal, the lower one the main signal. Use the EQs to adjust the sound to the room acoustics.
- 20 Press the **FBQ IN** switch to activate the FBQ Feedback Detection System. The frequencies causing feedback are shown by the brightly lit fader LEDs. Simply lower the level of the respective frequency range until feedback disappears and the LED goes out. Your power mixer offers this function both for the main and the monitor mix.
- 21 Turn the **FX RET** control to add the effect signal to the main mix (lower) or monitor mix (upper). The PMP980S/PMP1680S allows you to use two effects at the same time, it also has two FX controls each for the main and monitor mixes: when the FX RET 1 and FX RET 2 controls are fully counterclockwise, no effect signal is added.
- 22 The **CD/TAPE IN** control adjusts the volume of the 2 Track In signal (see 35).
- 23 The **MONITOR MASTER** control adjusts the monitor output volume.
- 24 Use this 5-digit LED meter to control the output level of the monitor signal. The upper LIM LED illuminates when the internal amp protection circuit responds to output levels that are too high.
- 25 The **MAIN MASTER** control is used to adjust the main output volume.
- 26 Use this 5-digit LED meter to control the output level of the main signal. The PMP980S/PMP1680S has two rows of LED meters (L/R), because the signal is stereo. The upper LIM LED illuminates when the internal amp protection circuit responds to output levels that are too high.
- 27 +48 V phantom power is provided for condenser microphones. The phantom power supply is activated for all channels with the **PHANTOM** switch and the PHANTOM LED above the switch illuminates.
- 28 Use the **POWER AMP** switch to determine the operating mode of your power mixer.

The PMP980S/PMP1680S has three different operating modes: In **MAIN L/MAIN R** mode it functions as a stereo amplifier, i.e. the left and right main stereo signals are sent to OUTPUT A (L) and OUTPUT B (R). In **MON/MONO** mode it functions as a dual mono amplifier, i.e. OUTPUT A sends the monitor signal, and OUTPUT B the main signal (mono). In **BRIDGE AMP MODE** the output power of outputs A and B are added and provided at OUTPUT B.

The PMP960M also has three operating modes, since it can be operated in two modes with the switch in its upper position (MAIN/MAIN (BRIDGE) mode), depending on the pin connections of the speaker cables. In **MAIN/MAIN (BRIDGE)** mode power of both outputs is added and provided at OUTPUT B (Locking cable, pins 1+/2+). With the normal pin connections (Locking cable, pins 1+/1-) a main signal is provided in this mode at OUTPUT A and B (not bridged). In **MON/MAIN** mode, the mixer can also be used as a dual mono amplifier, i.e. OUTPUT A provides the monitor signal, while the main signal is present at OUTPUT B.

Please refer to 44 and 45 as well as chapter 4.4 "Loudspeaker connectors".



- ◆ In **BRIDGE** mode, always connect only one loudspeaker with an impedance of at least 8 Ω to **OUTPUT B** (pins 1+/2+)! Please note that **OUTPUT A** must **NEVER** be used in **BRIDGE** mode (with pin connections 1+/2+)!
- ◆ In all other operating modes, the minimum impedance of the speaker connected must not fall below 4 Ω.

- 29 Use the **SPEAKER PROCESSING** switch to activate a filter that adapts the mixer to the specifications of your loudspeakers. If the speakers have a limited frequency response in the bass range, it allows you to adapt it optimally to the frequency response of the speakers.
- 30 If **STANDBY** is pressed, all input channels are muted. During breaks you can thus prevent the microphones from picking up noise or interference, which would then be reproduced by the P.A. system. The advantage is that all faders can be left untouched while you play a CD via the CD/TAPE inputs (see 35). There is also no need to move down the faders of muted channels and lose your mix.

### 2.3.1 Connectors

- 31 The **FOOTSWITCH** connector is for a standard footswitch. You can activate an "effect bypass" that mutes the effects processor. Please use a dual footswitch for the PMP980S/PMP1680S, so that you can enable/disable FX 1 and FX 2 independently of each other. In this case, the tip of the ¼" plug controls FX 1, and the ring FX 2.
- 32 The **FX OUT** connector is used to route the FX SEND signal from the input channels, for example, to the input of an external effects processor. The PMP980S/PMP1680S has two FX controls per input signal (see 5) and also two FX OUT connectors (**FX OUT 1** and **FX OUT 2**).
- ◆ Please note: When you connect a mono plug to one of the FX OUT jacks, the signal path from the respective FX send to the built-in effects processor is interrupted. For each FX send you can either use the built-in effect or the corresponding FX OUT jack (for an external effect), but never both at the same time. When you use a stereo plug (tip and ring interconnected) you can use the built-in effects processor and the FX OUT jacks in parallel.
- 33 Use the **AUX IN** ¼" inputs to route an external stereo signal to the main mix. This can be the signal generated by an external effects processor. Use the left input for mono signals, which are then reproduced on both stereo sides. The PMP960M has only one mono AUX IN connector.
- 34 The **AUX IN** control adjusts the volume of the external signal in the main mix.
- 35 The **CD/TAPE IN RCA** input allows you to feed in external stereo signals, e.g. from a CD player, tape deck or other line-level source.
- 36 The **VOICE CANCELLER** filters vocal-specific frequencies from the CD/TAPE IN signal. This function can be used for karaoke, i.e. you can remove the vocals from a song and then sing along with the music yourself.
- 37 The **REC OUT** (RCA) provides line-level signals from the power mixer to a DAT recorder, for example. On the PMP980S/PMP1680S the REC OUT signal is stereo and on the PMP960M two identical mono signals are provided.
- ◆ If the REC OUT signal is connected to a recorder whose output signal is returned to the CD/TAPE IN, feedback can occur when you activate the record function. So, disconnect the CD/TAPE IN from the recorder, before you start recording!
- 38 The **MAIN** ¼" connectors allow you to send the main signal to an external amplifier, when you only wish to use the mixer and effects section. The signal is taken pre-power stage of the mixer. It is also possible to use only the left jack of the output. The PMP960M has only one mono output connector.

- 39 Connect your monitor power amps or active monitor speakers to the mono **MONITOR** output to monitor the signal mix created with the MON controls or to route it to the musicians on stage.
- 40 Use the **POWER** switch to put the unit into operation. The POWER switch should always be in the "Off" position when you are about to connect the unit to the mains.
- ◆ Please note: The **POWER** switch does not fully disconnect the unit from the mains. Unplug the power cord completely when the unit is not used for prolonged periods of time.

### 2.4 Rear panel

- 41 The mains connection is on a standard **IEC** receptacle. An appropriate power cord is supplied with the unit.
- 42 **FUSE HOLDER.** Before connecting the unit to the mains, ensure that the voltage setting matches your local voltage. Blown fuses should only be replaced by fuses of the same type and rating. Please also read the information given in chapter 6 "Specifications".
- 43 **Loudspeaker OUTPUT A.**
- PMP980S/PMP1680S: Depending on the operating mode selected (see 28) either the left main signal or the monitor signal is provided at OUTPUT A. Never use this output in bridged mono mode.
- PMP960M: In MON/MAIN mode, the monitor signal is provided at OUTPUT A (see 28). Never use this output in bridged mono mode, except when you use a cable with the normal pin connections (pins 1+/1-). In this case you can take the mono main signal from this output in MAIN/MAIN (BRIDGE) mode (not bridged). Please also refer to chapter 4.3 "Loudspeaker connection".
- ◆ The impedance of the loudspeaker connected must not fall below 4 Ω.
  - ◆ Please note that the power delivered to the speaker in bridged mono mode is considerably higher than in other operating modes. Please read the information given on the rear panel of the power mixer.
- 44 **Loudspeaker OUTPUT B.**
- PMP980S/PMP1680S: Depending on the operating mode selected (see 28) either the right main signal, the mono main signal or the bridged mono signal is provided at OUTPUT B.
- PMP960M: Either the main or the bridged main mono signal is provided at OUTPUT B (see 28). When you use a cable with the normal pin connections (pins 1+/1-), it is possible in MAIN/MAIN (BRIDGE) mode to take the mono main signal from this output (not bridged). Please also refer to chapter 4.3 "Loudspeaker connection".
- ◆ In **BRIDGE** mode, always connect only one loudspeaker with an impedance of at least 8 Ω to **OUTPUT B** (pins 1+/2+)! Please note that **OUTPUT A** must **NEVER** be used in **BRIDGE** mode (with pin connections 1+/2+)!
  - ◆ In all other operating modes, the minimum impedance of the speaker connected must not fall below 4 Ω.
  - ◆ Information on how to properly connect your speaker with regard to polarity can be found on the rear of the mixer (PINOUTS).
- 45 **SERIAL NUMBER.**

### 3. Digital Effects Processor

#### 24-BIT MULTI-EFFECTS PROCESSOR

This built-in effects module produces high-grade standard effects such as reverb, chorus, flanger, delay and various combination effects. The integrated effects module has the advantage of requiring no wiring. This way, the danger of creating ground loops or uneven signal levels is eliminated at the outset, completely simplifying the handling.

These effect presets are designed to be added to dry signals. If you move the FX RET control, you mix the channel signal (dry) and the effect signal.

- ◆ Turn down the FX controls in those channel strips whose signals you don't wish to process.

### 4. Installation

#### 4.1 Mains connection

Blown fuses must be replaced by fuses of the same type and rating.

The mains connection is made using the enclosed power cord and a standard IEC receptacle. It meets all of the international safety certification requirements.

- ◆ Please make sure that all units have a proper ground connection. For your own safety, never remove or disable the ground conductor from the unit or of the AC power cord.

#### 4.2 Audio connections

The inputs and outputs of the BEHRINGER EUROPOWER are unbalanced 1/4" TS connectors—except for the balanced mono line inputs. Of course, all inputs and outputs work with both balanced and unbalanced connectors. The Tape Ins and Outs are on stereo RCA connectors.

- ◆ Please ensure that only qualified personnel install and operate the power mixer. During installation and operation, the user must have sufficient electrical contact to earth. Electrostatic charges might affect the operation of the unit.

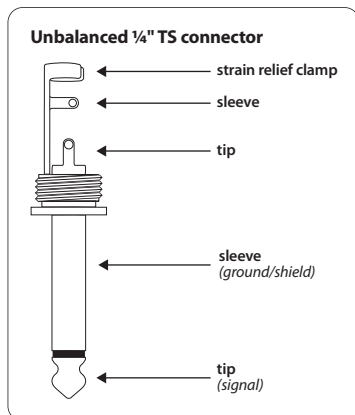

Fig. 4.1: 1/4" TS connector

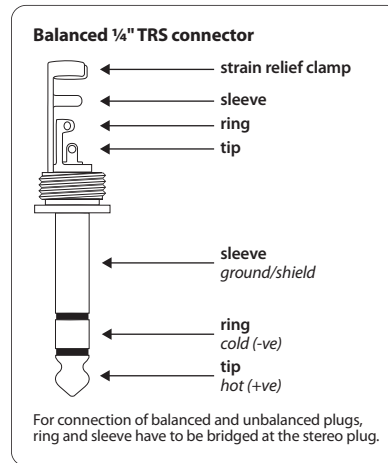

Fig. 4.2: 1/4" TRS connector

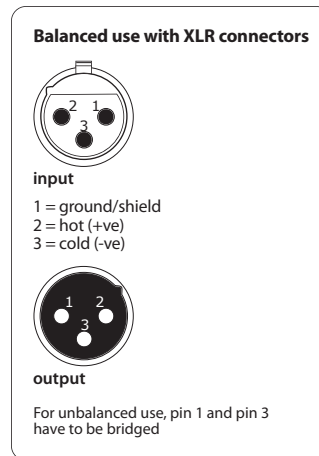

Fig. 4.3: XLR connectors

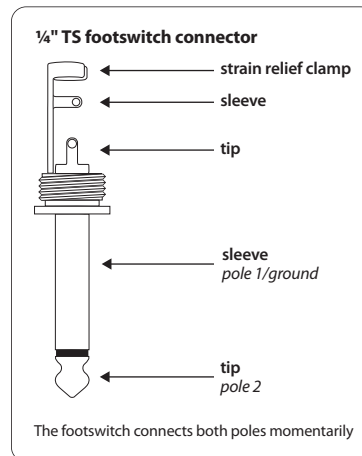

Fig. 4.4: 1/4" TS connector for footswitch



◆ Please use a dual footswitch for the PMP980S/PMP1680S, so that you can enable/disable FX 1 and FX 2 independently of each other. In this case, the tip of the ¼" plug controls FX 1, and the ring FX 2.

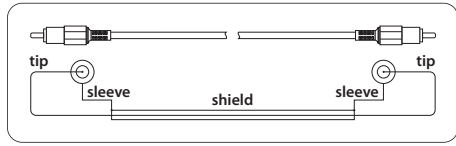

Fig. 4.5: RCA cable

### 4.3 Loudspeaker connection

Your PMP mixer is equipped with high-quality twist-lock professional style loudspeaker connectors, which ensure safe and trouble-free operation. This connector was especially developed for high-power loudspeakers. Once it is plugged in, it safely locks into position and cannot be accidentally disengaged. It prevents the occurrence of electrical shock and ensures the correct polarity. Each of the connectors carries only the assigned single signal (see tab. 4.1/fig. 4.7 and the information on the rear panel of the power mixer).

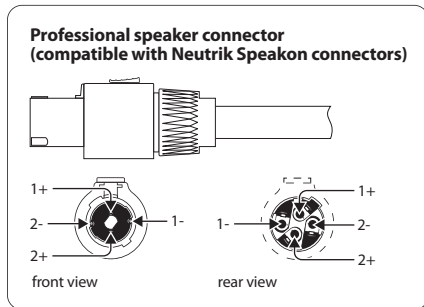

Fig. 4.6: Professional twist-lock style connector

Please be sure to only use professional locking-style speaker cables (type NL4FC). Please check the pin connections of your loudspeakers and cables depending on the EUROPOWER speaker output you choose.

#### EUROPOWER PMP980S/PMP1680S

OUPUT A	1+	1-	2+	2-
MAIN L	POS	NEG	-	-
MON	POS	NEG	-	-
OUTPUT B	-	-	POS	NEG
OUTPUT B	1+	1-	2+	2-
MAIN R	POS	NEG	-	-
MONO	POS	NEG	-	-
BRIDGE	POS	-	NEG	-

#### EUROPOWER PMP960M

OUTPUT A	1+	1-	2+	2-
MAIN MONO	POS	NEG	-	-
MON	POS	NEG	-	-
BRIDGE	-	-	-	-
OUTPUT B	1+	1-	2+	2-
MAIN MONO	POS	NEG	-	-
MAIN	POS	NEG	-	-
BRIDGE	POS	-	NEG	-

Tab 4.1: Pin connections of loudspeaker connectors

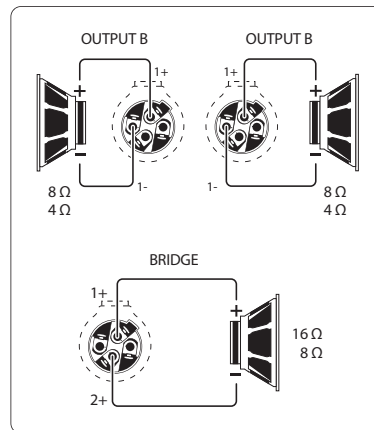



Fig. 4.7: Connector assignment

## 5. Wiring Examples

For stereo operation the POWER AMP switch  of the PMP980S/PMP1680S must be set to its upper position (MAIN L/MAIN R). Outputs A and B deliver the stereo main signal to the P.A. speakers. Two active speakers, wired in parallel, are connected to the preamp monitor output. They are used as on-stage monitor speakers. The effects processors can be switched on and off with a dual footswitch. This set-up is not possible with the PMP960M (no stereo operation possible).

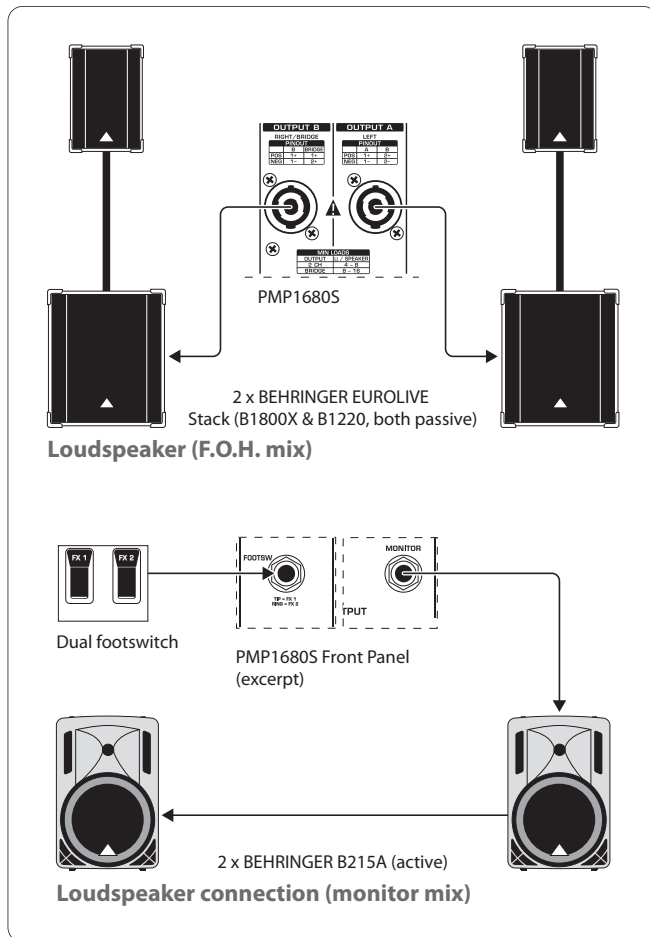



Fig. 5.1: EUROPOWER mixer as a stereo amplifier (example)

Both the PMP980S/PMP1680S and the PMP960M can be set-up for dual mono operations. The POWER AMP switch  must be set to its lower (PMP960M) or center position (PMP980S/PMP1680S). The two loudspeaker outputs provide the main and monitor signals independently of each other and to two loudspeakers each, which are wired in parallel.

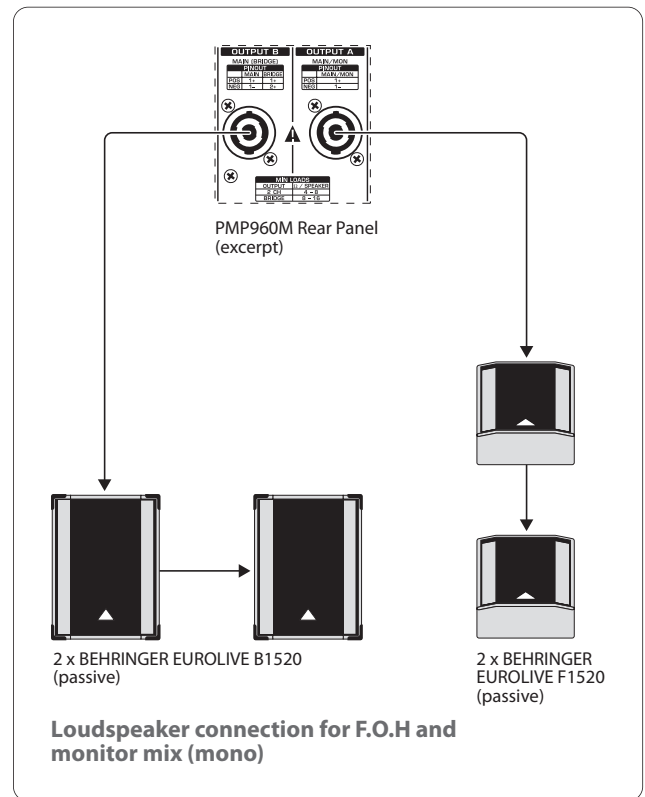

Fig. 5.2: EUROPOWER as a dual mono amplifier (example)

This illustration shows just one example of how the channels of your power mixer can be used, including the connection of mono and stereo sources, and the tape ins and outs recording the mix signal or playing back external signals.

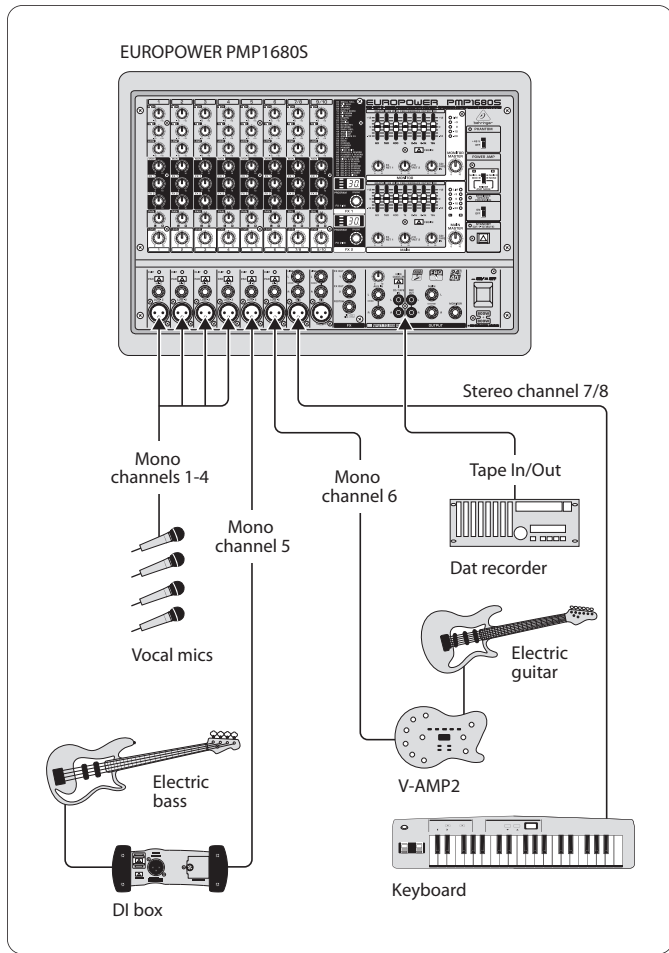

Fig. 5.3: Standard set-up (example)

One example of how to use your power mixer with a subwoofer in bridged mono mode. The illustration shows the PMP1680S with a subwoofer connected to OUTPUT B that will receive the full (bridged) output power. A separate stereo power amp (BEHRINGER EUROPOWER EP2000) for the stereo main P.A. signal is connected to the Pre Amp Main outputs. The Pre Amp monitor output is wired to active speakers on the stage. This application can also be realized with the PMP960M, except for the main P.A. signal, which would be mono.

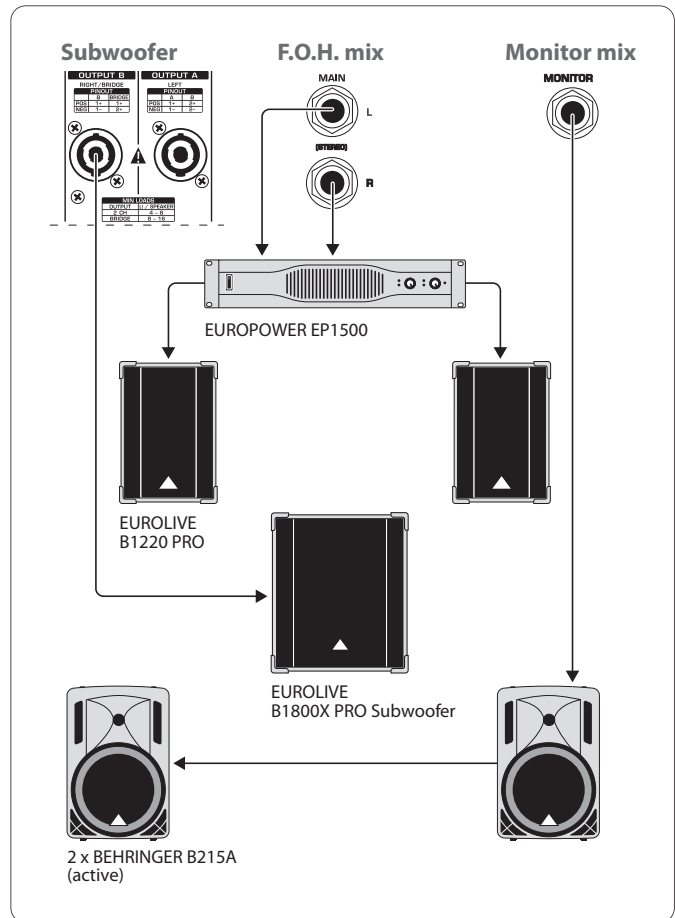

Fig. 5.4: EUROPOWER in bridged mono mode

## 6. Specifications

### Microphone Inputs

Type	XLR, electronically balanced input circuit
<b>Mic E.I.N. (20 Hz - 20 kHz)</b>	
@ 0 Ohm source resistance	-112 dB / 114 dB A-weighted
@ 50 Ohm source resistance	-112 dB / 114 dB A-weighted
@ 150 Ohm source resistance	-112 dB / 114 dB A-weighted
Frequency response	< 10 Hz - 200 kHz (-1 dB) < 10 Hz - > 200 kHz (-3 dB)
Gain	+30 dB, +10 dB with pad
Max. input level	+12 dBu @ +10 dB gain
Impedance	approx. 2.2 kOhm balanced / approx. 1.1 kOhm unbalanced
Signal-to-noise ratio	110 dB / 114 dB A-weighted (0 dBu In @ +10 dB gain)
Noise (THD + N)	0.001% / 0.0007% A-weighted

### Mono Line Inputs

Type	¼" TS connectors, balanced
Impedance	approx. 20 kOhm, balanced
Max. input level	+21 dBu

### Stereo Line Inputs

#### PMP980S/PMP1680S

Type	¼" TRS connectors, unbalanced
Impedance	approx. 100 kOhm, unbalanced
Max. input level	+21 dBu

### Equalizer

Low	80 Hz / +/-15 dB
Mid	2.5 kHz / +/-15 dB
High	12 kHz / +/-15 dB

### CD/TAPE Input

Type	RCA
Impedance	approx. 10 kOhm

### Preamp Outputs

#### MAIN

Type	¼" TS connectors, unbalanced
Impedance	approx. 150 Ohm, unbalanced
Max. output level	+21 dBu

#### MONITOR

Type	¼" TS connectors, unbalanced
Impedance	approx. 150 Ohm, unbalanced
Max. output level	+21 dBu

### Stereo Outputs

#### PMP960M

Type	RCA, mono output
Impedance	approx. 1 kOhm
Max. input level	+21 dBu

#### PMP980S/PMP1680S

Type	¼" TRS connectors, unbalanced
Impedance	approx. 150 Ohm, unbalanced
Max. input level	+21 dBu
Type	RCA
Impedance	approx. 1 kOhm
Max. input level	+21 dBu

### Main Mix System Data

#### Noise:

MAIN MIX @ -∞ Channel fader -∞	-102 dB/-106 dB A-weighted
MAIN MIX @ 0 dB Channel fader -∞	-88 dB/-91 dB A-weighted
MAIN MIX @ 0 dB Channel fader @ 0 dB	-84 dB/-86 dB A-weighted

### Loudspeaker Outputs

Type	Neutrik Speakon-compatible connector
------	--------------------------------------

#### Load impedance:

MAIN L/R	4 - 8 Ohm
MONITOR/MAIN MONO	4 - 8 Ohm
MAIN MONO/MAIN MONO	4 - 8 Ohm
BRIDGE	8 - 16 Ohm

**DSP**

Converter	24-bit Delta-Sigma, 64/128-times oversampling
Dynamics D/A	90 dB
Sampling rate	40 kHz
Delay Time	max. 5 secs
Signal run time (Line In > Line Out)	approx. 1.5 ms

**Display****PMP960M**

Type	2-digit, 7-segment LED
------	------------------------

**PMP980S/PMP1680S**

Type	2 x 2-digit, 7-segment LED
------	----------------------------

**Output Power****PMP960M/PMP980S****RMS @ 1% THD (sine wave), both channels driven:**

8 Ohm per channel	160 W
4 Ohm per channel	300 W

**RMS @ 1% THD (sine wave), bridged mode:**

8 Ohm	600 W
-------	-------

**Peak Power, both channels driven:**

8 Ohm per channel	260 W
4 Ohm per channel	450 W

**Peak Power, bridged mode:**

8 Ohm	900 W
-------	-------

**PMP1680S****RMS @ 1% THD (sine wave), both channels driven:**

8 Ohm per channel	300 W
4 Ohm per channel	600 W

**RMS @ 1% THD (sine wave), bridged mode:**

8 Ohm	1200 W
-------	--------

**Peak Power, both channels driven:**

8 Ohm per channel	400 W
4 Ohm per channel	800 W

**Peak Power, bridged mode:**

8 Ohm	1600 W
-------	--------

**Fuses****PMP1680S**

100 - 120 V~, 50/60 Hz	T 10 A H 250 V
220 - 240 V~, 50/60 Hz	T 6.3 A H 250 V

**Power Consumption**

Power consumption	1000 W
Mains connector	IEC standard receptacle

**Dimensions/Weight**

Dimensions (H x W x D)	approx. 315 x 460 x 220 mm (approx. 12 <sup>2</sup> / <sub>5</sub> x 18 <sup>1</sup> / <sub>10</sub> x 8 <sup>3</sup> / <sub>5</sub> "
------------------------	---

**PMP960M**

Weight	8.5 kg (18 <sup>3</sup> / <sub>4</sub> lbs)
--------	---

**PMP980S**

Weight	9.4 kg (20 <sup>3</sup> / <sub>4</sub> lbs)
--------	---

**PMP1680S**

Weight	9.9 kg (21 <sup>4</sup> / <sub>5</sub> lbs)
--------	---

BEHRINGER is constantly striving to maintain the highest professional standards. As a result of these efforts, modifications may be made from time to time to existing products without prior notice. Specifications and appearance may differ from those listed or illustrated.

# FEDERAL COMMUNICATIONS COMMISSION COMPLIANCE INFORMATION



Responsible Party Name: **MUSIC Group Services US Inc.**

Address: **18912 North Creek Parkway,  
Suite 200 Bothell, WA 98011,  
USA**

Phone Number: **+1 425 672 0816**

## **EUROPOWER PMP1680S/PMP980S/PMP960M**

complies with the FCC rules as mentioned in the following paragraph:

This equipment has been tested and found to comply with the limits for a Class B digital device, pursuant to part 15 of the FCC Rules. These limits are designed to provide reasonable protection against harmful interference in a residential installation. This equipment generates, uses and can radiate radio frequency energy and, if not installed and used in accordance with the instructions, may cause harmful interference to radio communications. However, there is no guarantee that interference will not occur in a particular installation. If this equipment does cause harmful interference to radio or television reception, which can be determined by turning the equipment off and on, the user is encouraged to try to correct the interference by one or more of the following measures:

- Reorient or relocate the receiving antenna.
- Increase the separation between the equipment and receiver.
- Connect the equipment into an outlet on a circuit different from that to which the receiver is connected.
- Consult the dealer or an experienced radio/TV technician for help.

This device complies with Part 15 of the FCC rules. Operation is subject to the following two conditions:

- (1) this device may not cause harmful interference, and
- (2) this device must accept any interference received, including interference that may cause undesired operation.

### **Important information:**

Changes or modifications to the equipment not expressly approved by MUSIC Group can void the user's authority to use the equipment.





We Hear You